

SIDE-POWER
Thruster Systems

SRV(P) 80/185 T
SRL(P) 80/185 T
SRV(P) 100/185 T
SRL(P) 100/185 T

EN Installation & User Guide v1.1.9



SRL



SRV



Sailtec GmbH
Hasselbinnen 28
D-22869 Schenefeld

+49 (0)40-822 994 0
info@sailtec.de
www.sailtec.de



Patent nr/EP2548797



SLEIPNER MOTOR AS

P.O. Box 519
N-1612 Fredrikstad
Norway

Tel: +47 69 30 00 60
Fax: +47 69 30 00 70

www.side-power.com
sidepower@sleipner.no



Made in Norway

© Sleipner Motor AS 2016

Installation instructions

Measurements, thruster.....	3
Planning and important precautions	5
Technical specifications	6

Thruster installation

Step by step installation	7
Fitting the electromotor	18
Electrical installation	19
150000 controller.....	20
Technical & visual wiring diagrams, SRV/SRL models.....	21
Technical & visual wiring diagrams, SRVP/SRLP models.....	22
Check and calibrate drive shaft alignment.....	23
Maintenance	24

S-Link

S-link system overview	25
------------------------------	----

User's manual

Control panels	27
General use	28
Installation checklist.....	29
Important user precautions.....	30
Troubleshooting.....	31

Warranty statement	32
---------------------------------	----

Spareparts lists & drawings	33
--	----

DECLARATION OF CONFORMITY

We, Sleipner Motor AS
P.O. Box 519
N-1612 Fredrikstad, Norway

declare that this product with accompanying
standard remote control systems complies with
the essential health and safety requirements
according to the Directive 89/336/EEC of 23
May 1989 amended by 92/31/EEC and
93/68/EEC.

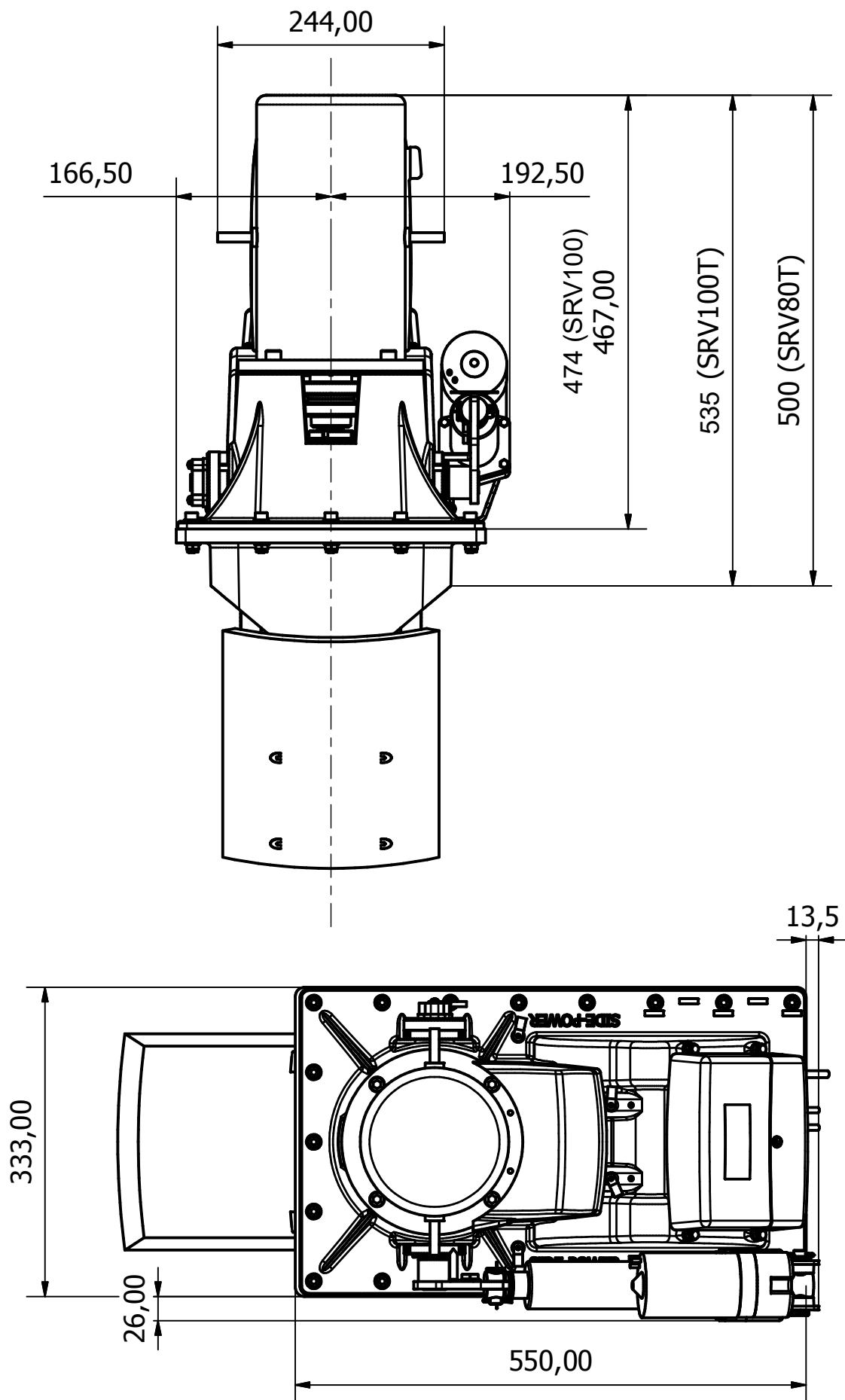

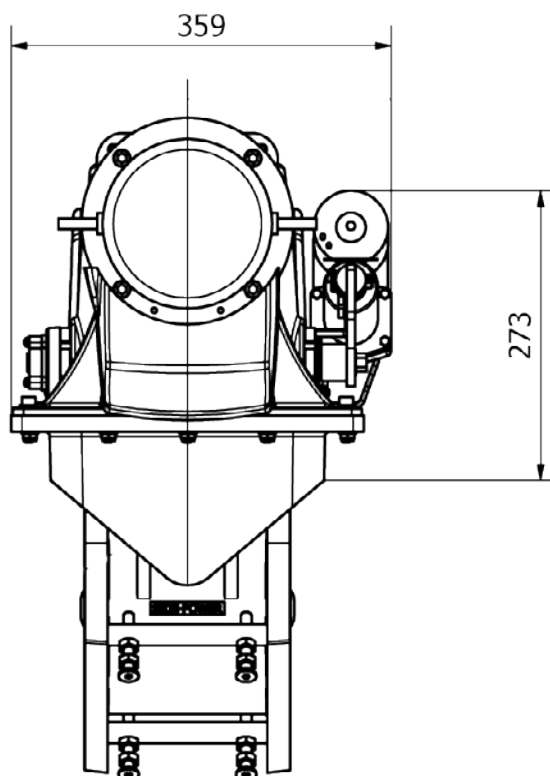
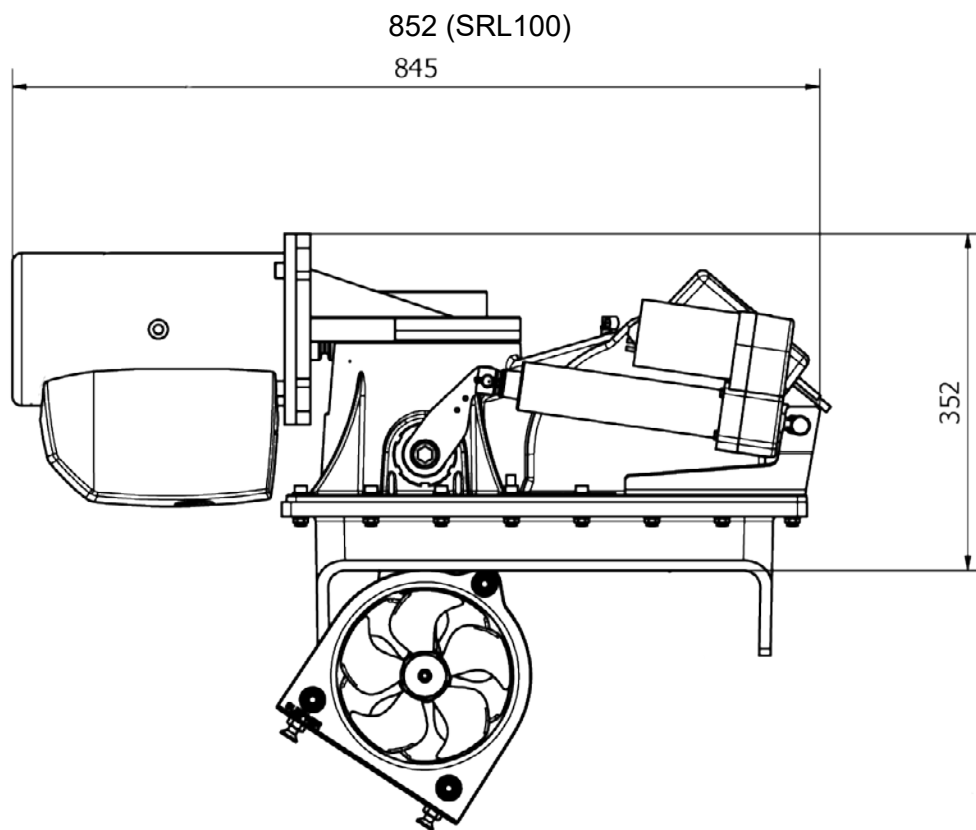

Prior to installation, it is important that the installer reads this guide to ensure necessary acquaintance with this product.

- ⚠ The thruster must NOT be installed in compartments that require ignition proof electric equipment. If necessary, make a separate compartment.
- ⚠ The electromotor will generate some carbon dust so that any storage compartment must be separated from the thruster to prevent the stored items from becoming dusty/dirty.
- ⚠ If you are installing the Sidepower in a small room /compartment, it should be ventilated to ensure cooling of the electromotor.
- ⚠ If the height in the room you are installing the Sidepower is limited, the Sidepower can be installed horizontally or at any angle in between.
 - If the electro motor is positioned more than 30° off vertical, it must be supported separately.
 - The electromotor must be handled carefully. Do not lift it by the internal connections/main terminals or put it down on the driveshaft.
 - Beware to keep installation within advised measurements. No part of the propeller or gearhouse must be outside the tunnel.
- ⚠ The electromotor, its components, contacts / plugs or other joints in the control cables must be mounted so that they will keep dry at all times.
- ⚠ We advice to paint the gearhouse and propellers with antifouling. PS! Do not paint the zinc anodes, sealings or propellershafts.
- ⚠ Do not finish the inside of the tunnel with a layer of gelcoat / topcoat or similar. It is only room for a thin layer of primer and two layers of anti-fouling between the tunnel and the props.
- ⚠ With the boat on land, only run the thruster for a fraction of a second, as without resistance it will accelerate very fast to a damaging rpm. Also, while the thruster is in air, make sure that the propellers have come to a complete stop before performing a directions change of the thruster, as it might cause damage to the thruster.
- ⚠ This manual is intended to support educated/experienced staff and is therefore not sufficient in all details for the correct installation.
- ⚠ Don't install the electromotor at close range to easily flammable objects as it will reach over 100°C before the temperature switch is activated.
- ⚠ Do not store items close to the thruster motor as it gets hot as well as any loose items near the thruster motor can cause problems with electrical wiring coming loose and short-circuiting.
- ⚠ When installed in boats approved or classified according to international or special national rules, the installer is responsible for following the demands in accordance with these regulations / classification rules. The instructions in this guide can not be guaranteed to comply with all different regulations/classification rules.
- ⚠ These instructions are only general instruction. If you are not skilled to do this work, please contact professional installers for assistance.

NB! Faulty installation of the tunnel/case, thruster or panel will render all warranty given by Sleipner Motor AS void.

Precautions with Stern installation

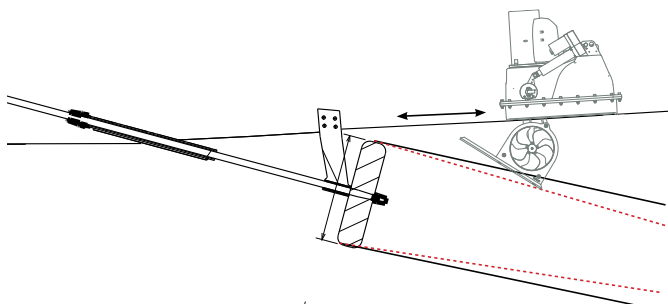

IMPORTANT!
If thruster will be stern mounted, propeller/water stream and thruster position must be considered by a Naval Architect regarding exact positioning of the thruster. This to avoid conflicts that will cause extra wear on thruster mechanics and reduced power on the vessels propeller.

IMPORTANT!
Fig1b is just an example of thruster positioned outside of conflict area. Detailed measurements must be done by boatbuilder. Propeller size and shaft angle will affect positioning the thruster.

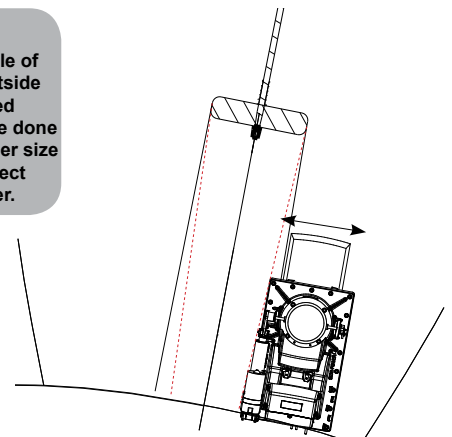
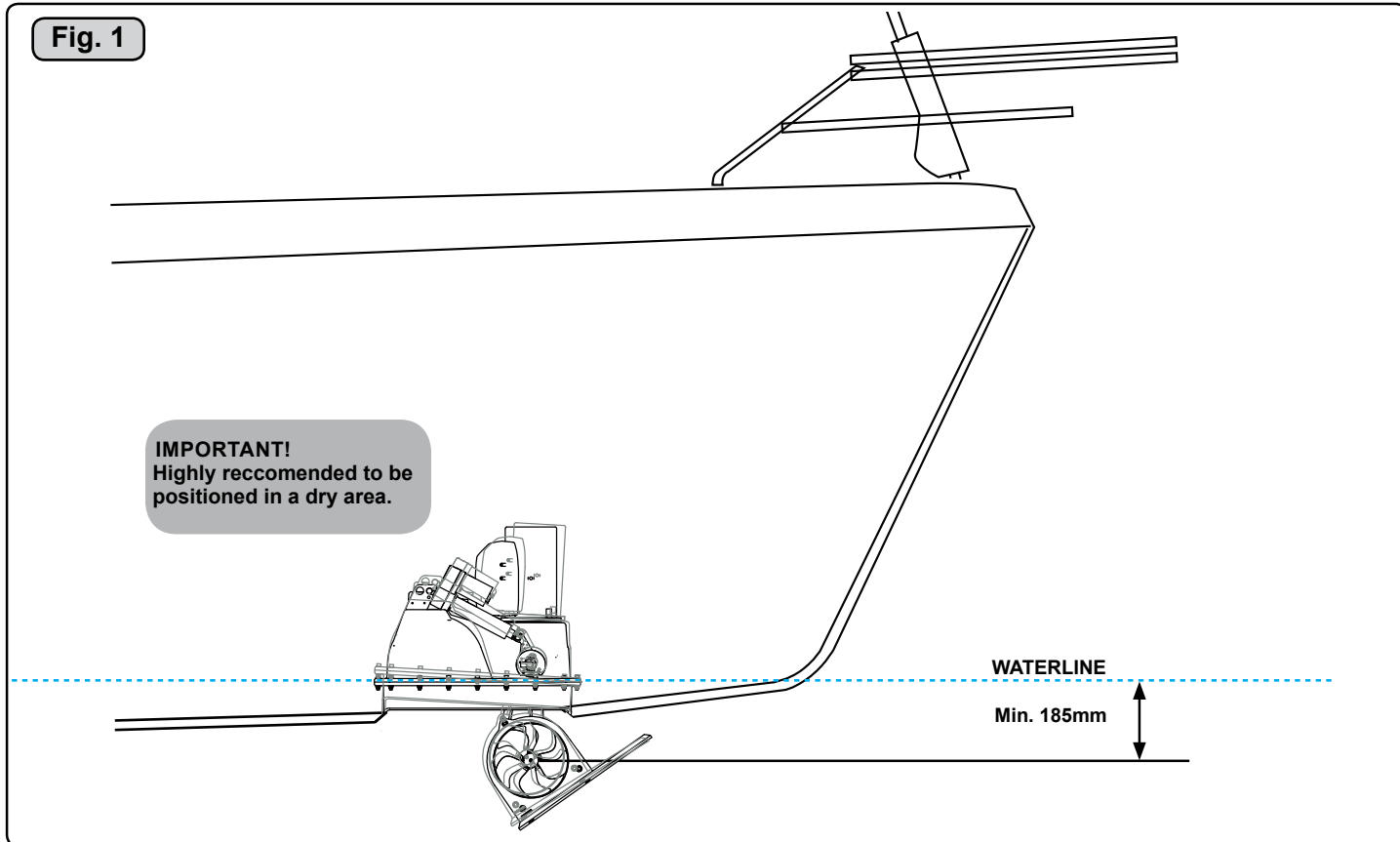

Fig. 1



EN

Technical specifications

TYPE

SRV/SRL Thruster with one speed

TYPE

SRVP/SRLP: Thruster with speed control

Motor: Custom made reversible DC-motor.

Gearhouse: Seawater resistant bronze. Ballbearing at propellershaft and combination of ballbearing and slide bearing at driveshaft. Galvanically separated from the motor.

Tunnel: Fibreglass reinforced polyamid

Propeller: 5 blade skew "Q"-propeller, fibreglass reinforced composite.

Batteries: Minimum recommended battery capacity - See table in the electrical installation section.

Max. use: S2 = 3 min. or appr. 7-10% within a limited time frame.

(The actual duty time will vary - depending on ventilation level, depth of thruster and actual delivered voltage to thruster)

Safety: Electronic time-delay device protects against sudden change of drive direction. Electric thermal cut-off switch in electromotor protects against over heating (auto reset when electro motor cools down). Flexible coupling between electro-motor and driveshaft protects electromotor and gearsystem if propeller gets jammed.

After a preset time in the panel (depending on panel model), the panel will turn off, and the thruster will retract. The thruster will automatically retract when the panel is turned off (manual or automatic)

Integrated microprocessor monitors solenoids, reducing wear and risk of solenoid lock-in. Auto-stop of thruster in case of accidental solenoid lock-in.

The thruster must be mounted in the direction shown on **Fig. 1/1b**, both if mounted in bow and stern (the hatch must open towards the direction of travel).

If the unit is to be used as a bow thruster, find the position furthest forward where the unit will fit - allowing for 10cm space around all sides of the unit for moulding, but not so far forward that the propeller will not go deep enough in the water. Mounting the unit further forward will give less depth for the propeller, but better leverage effect for turning the boat in crosswinds. Used as a stern thruster, the unit should be placed as far aft as possible.

Check the space requirements inside for the height, and propeller depth under the waterline.

Find the most forward position where thruster unit will fit, so center of the deployed thruster tunnel is at minimum **185mm** under the waterline.

Place unit where intended, take necessary measurements to check that the complete unit with motor, relay cover and actuator(s) fit in the designated space for installation and service access. It is highly recommended that the area is dry at all times, and the thruster do NOT get exposed to water.

Fig. 1b

Ensure to position the thruster correctly to avoid conflict between hatch and hull when the thruster is in OUT position!

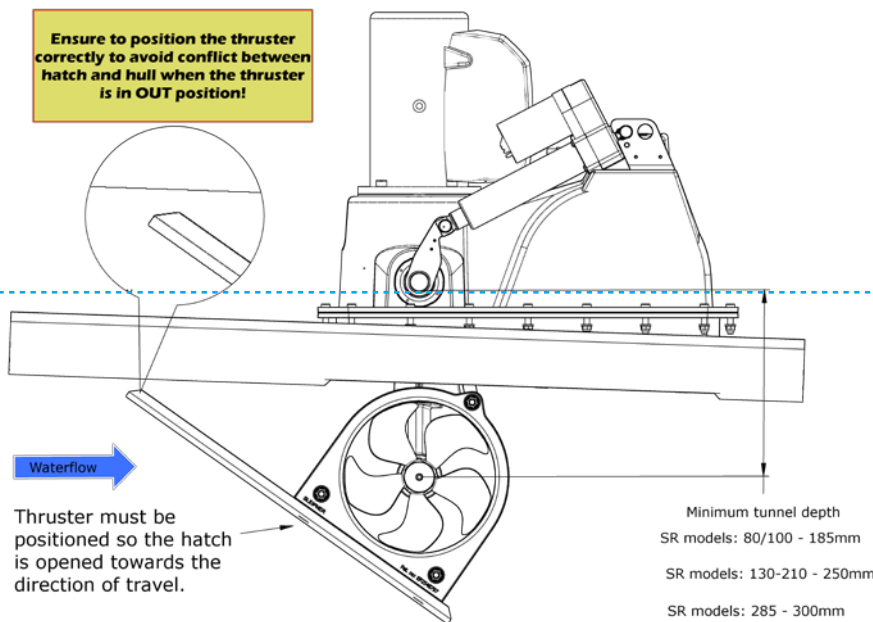

1. When correct position of thruster is decided, use the SRF flange to mark inside hatch cutting lines as thruster positioning reference. Mark centerlines on SRF flange and hull. **Fig. 2/2b**

IMPORTANT!

If hull is made of sandwich materials, ensure to remove sandwich materials and prepare moulding area for GRP moulding process. This is the installer/boatbuilder full responsibility.

Fig. 2

Find correct position for the thruster - And by using the SRF flange, mark inside cutting lines as positioning reference

Ensure to have a minimum of 100mm space around the thruster installation in order to have service access.

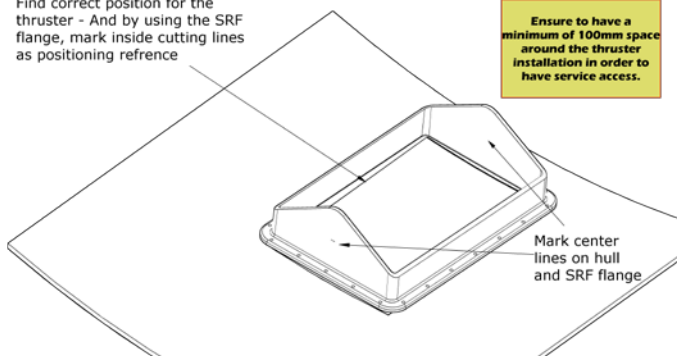
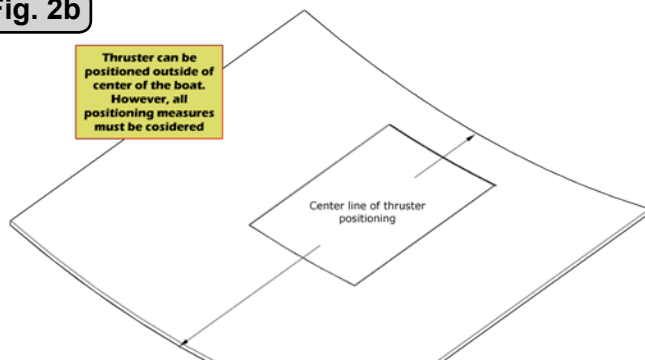

Fig. 2b

Thruster can be positioned outside of center of the boat. However, all positioning measures must be considered



2. To find correct installation height/SRF flange adjustment, place the thruster in center of marked position with tunnel rings sitting parallel to hull. **Fig. 3**

Red installation part is sitting inside of upper case and will ensure the installation height will be correct. Remember to remove the part when installation process is completed! See Appendix 1.

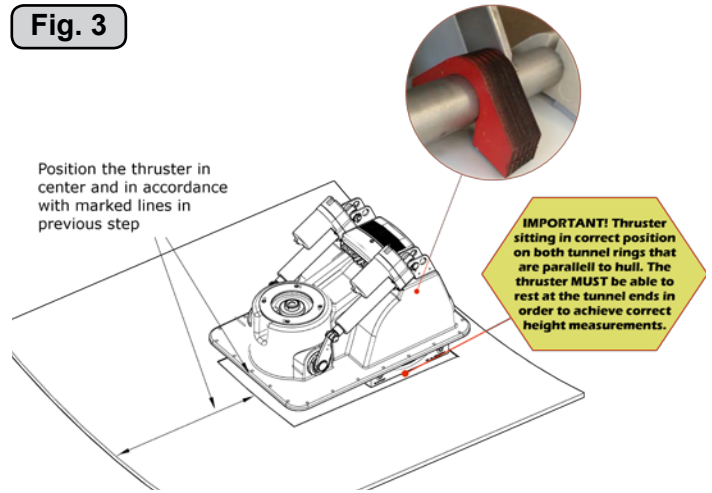

3. Measure distances from upper flange edges down to hull as illustrated in **Fig 4**. Type the measurements on hull to easily transfer them to the SRF flange.

Important! When measuring ensure the tunnel rings are sitting parallel to hull.

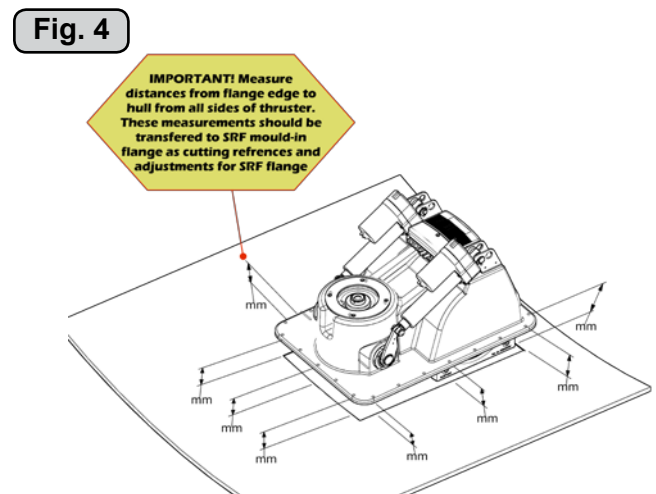

4. Transfer measurements to SRF flange and start cutting/adjusting the SRF flange. **Fig. 5**.

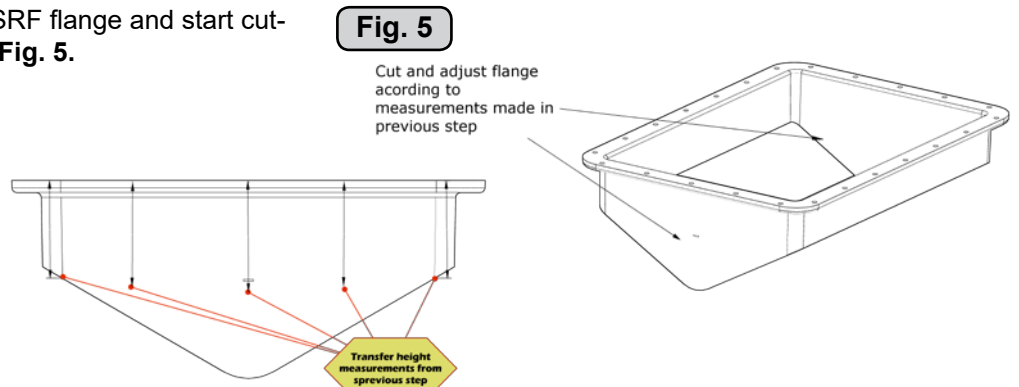

5. After cutting/adjusting the SRF flange, place the unit in correct direction and ensure the cutting is correct and suited to the hull's shape. **Fig. 6**.

Important! Measure and control that correct height is achieved in accordance with Appendix 1.

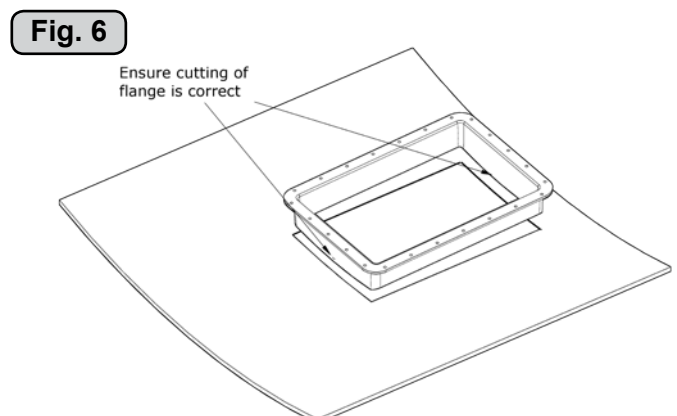

6. The hatch can be cut out either from outside or inside the boat. If cutting from outside, it will be practical to drill 4xØ3mm holes in each corner, so it will be easy to make the cutting/reference lines from outside. **Fig. 7.**

Fig. 7

Drill 4 Ø3mm reference holes in each corner. In case of outside cutting of hatch.

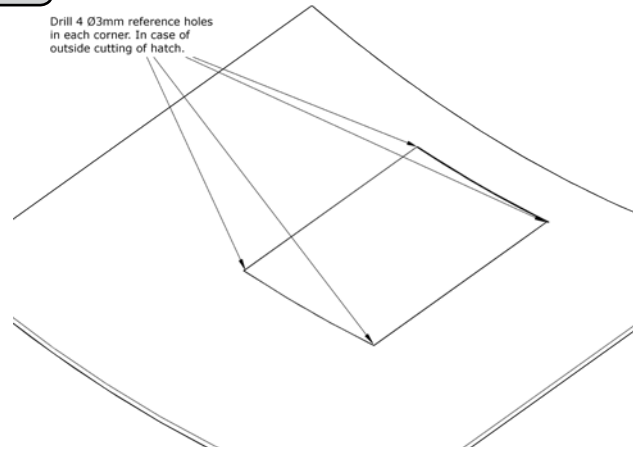

7. When cutting out the hatch use a suitable cutting tool (with correct angle guide) and gently cut out the hatch in accordance with **Fig. 8/b/c.**

Fig. 8

Important! When cutting use a suitable guide tool ensuring to get the correct cutting angles

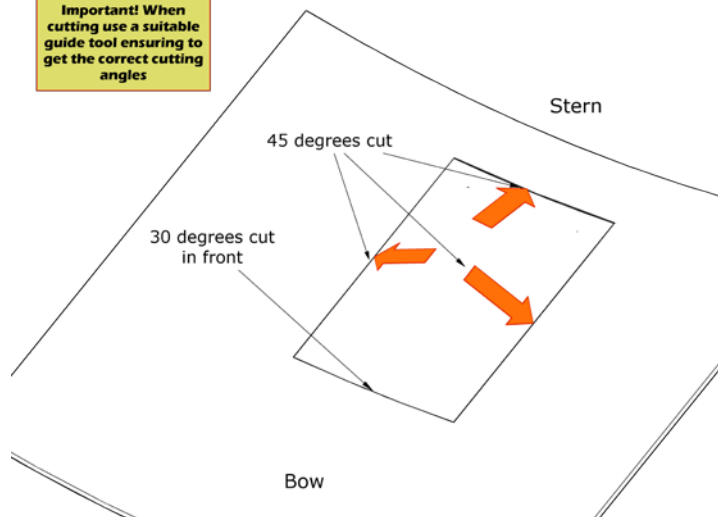

Important! Cut the front and the back sides of the hatch according to Fig. 8b(Side View). The front cut at 30° chamfer is for optimal release of the hatch. Bow is indicated as the direction of travel.

Fig. 8b

Side View

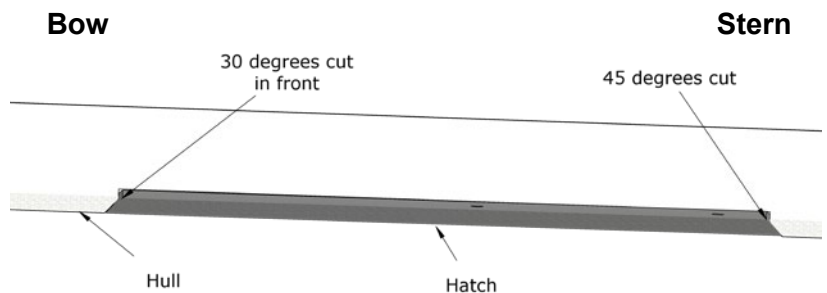

Important! Cut the illustrated sides in a 45° chamfer according to Fig. 8c.

Fig. 8c

Front View

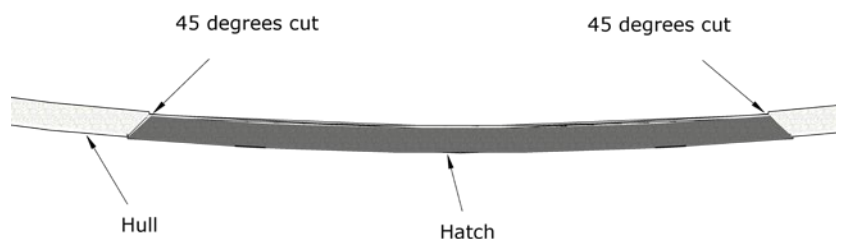

Important! Ensure when completing the cutting, that the hatch does not drop and get damaged.

8. Before moulding process ensure to go through the positioning check points in Appendix 3.

- Inside and outside moulding surfaces must be grinded to remove coating and material in order to get correct adhesion preparations for moulding in the SRF flange to hull. **Fig. 9.** See appendix 2.

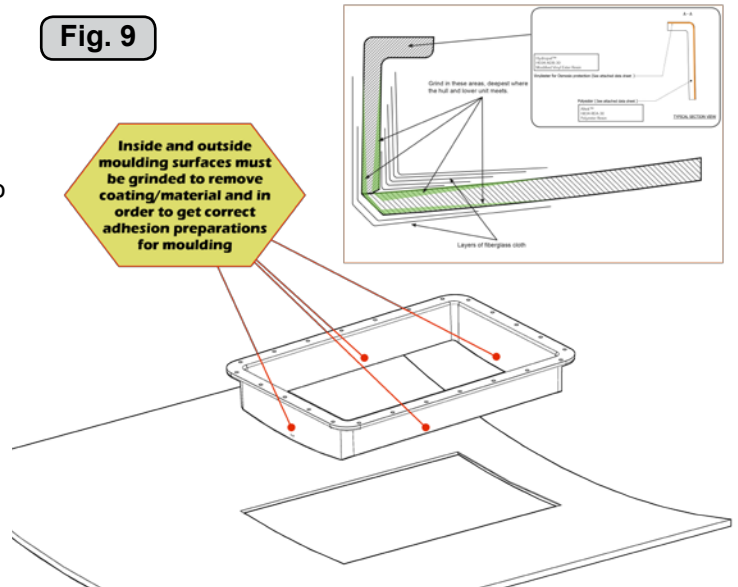

9. Apply Epoxy filler or equivalent on bottom edges of SRF for bonding between hull and SRF flange. Ensure that filler is compatible with hull materials. This is the boatbuilder/installer full responsibility. **Fig. 10.** See appendix 2.

Fig. 10

Apply Epoxy filler or equivalent for bonding between hull and SRF flange

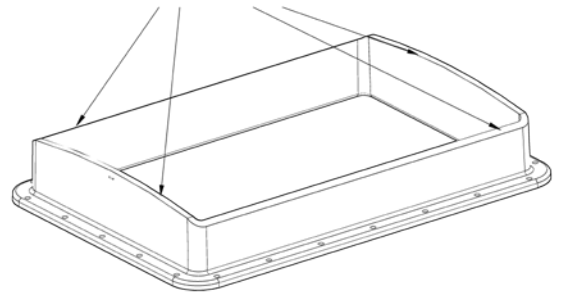

10. Position the SRF flange with the upper thruster case resting on the SRF flange (Fitted with 4 x bolts). Ensure the SRF flange is sitting in correct position, and then fill gaps between SRF and hull with Epoxy filler or equivalent. Grind and smoothen surfaces after curing time. **Fig. 11.**

Fig. 11

Important! Do NOT remove upper thruster case before curing time is over.

Fill all gaps with Epoxy filler or equivalent, with thruster case resting on SRF flange. Grind and smoothen surfaces after curing time.

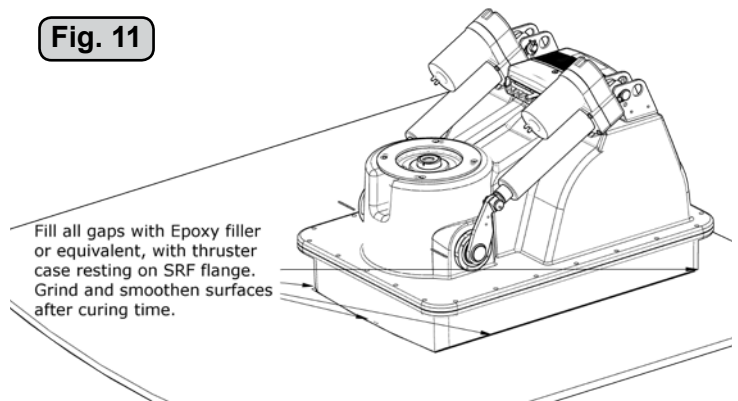

11. Apply layers of fibre glass in accordance with data sheet (Appendix 1). Ensure that resin is compatible with hull materials. This is the boatbuilder/installer full responsibility. **Fig. 12.**

Fig. 12

- Smoothen all moulded surfaces.

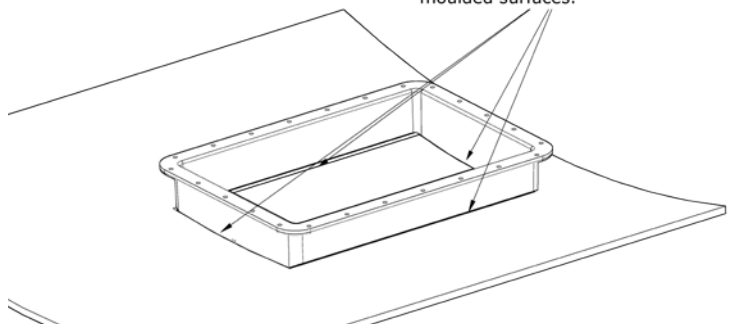

12. After curing time, smoothen all moulded surfaces and apply coating. **Fig. 13.**

Fig. 13

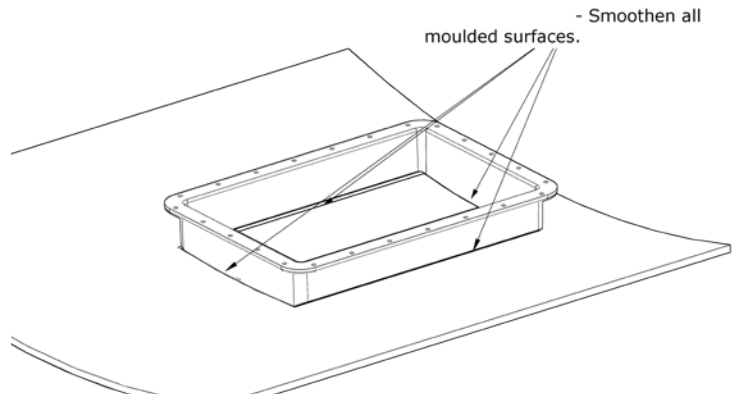

Appendix 1.

A-A (0,16 : 1)

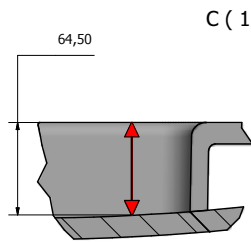
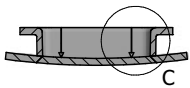

C (1 : 2)

IMPORTANT!
 Lowest contact point on tunnel rings and up to flange edge must be minimum 64,5mm . It can be higher and angled, however an suitable filler/material must be added to ensure a solid fit if this is present.

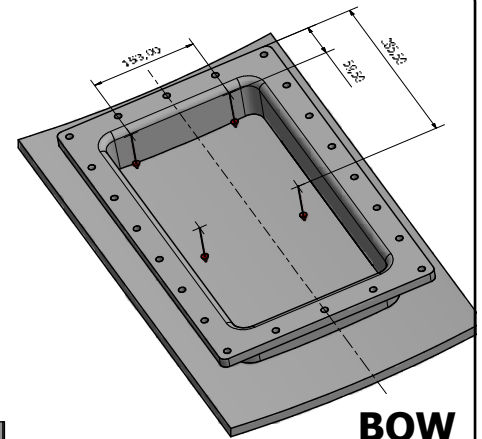

B-B (0,16 : 1)

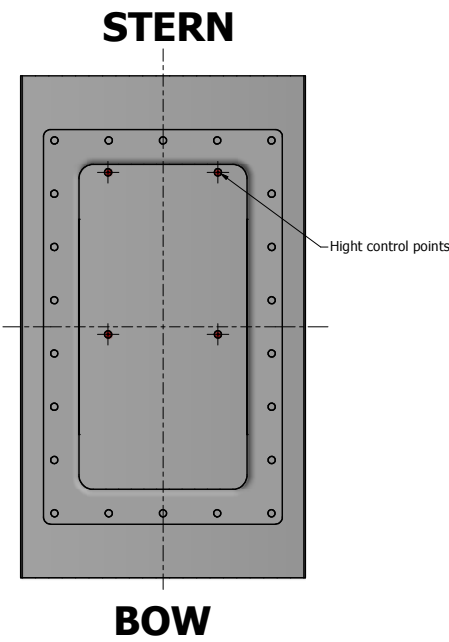
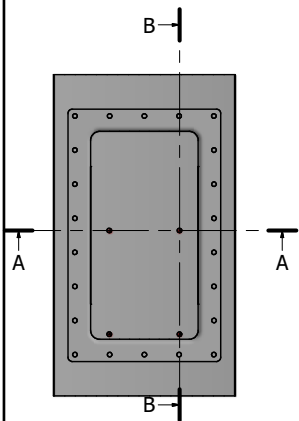
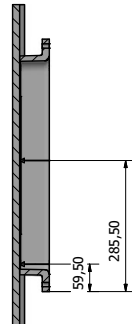

Appendix 2.

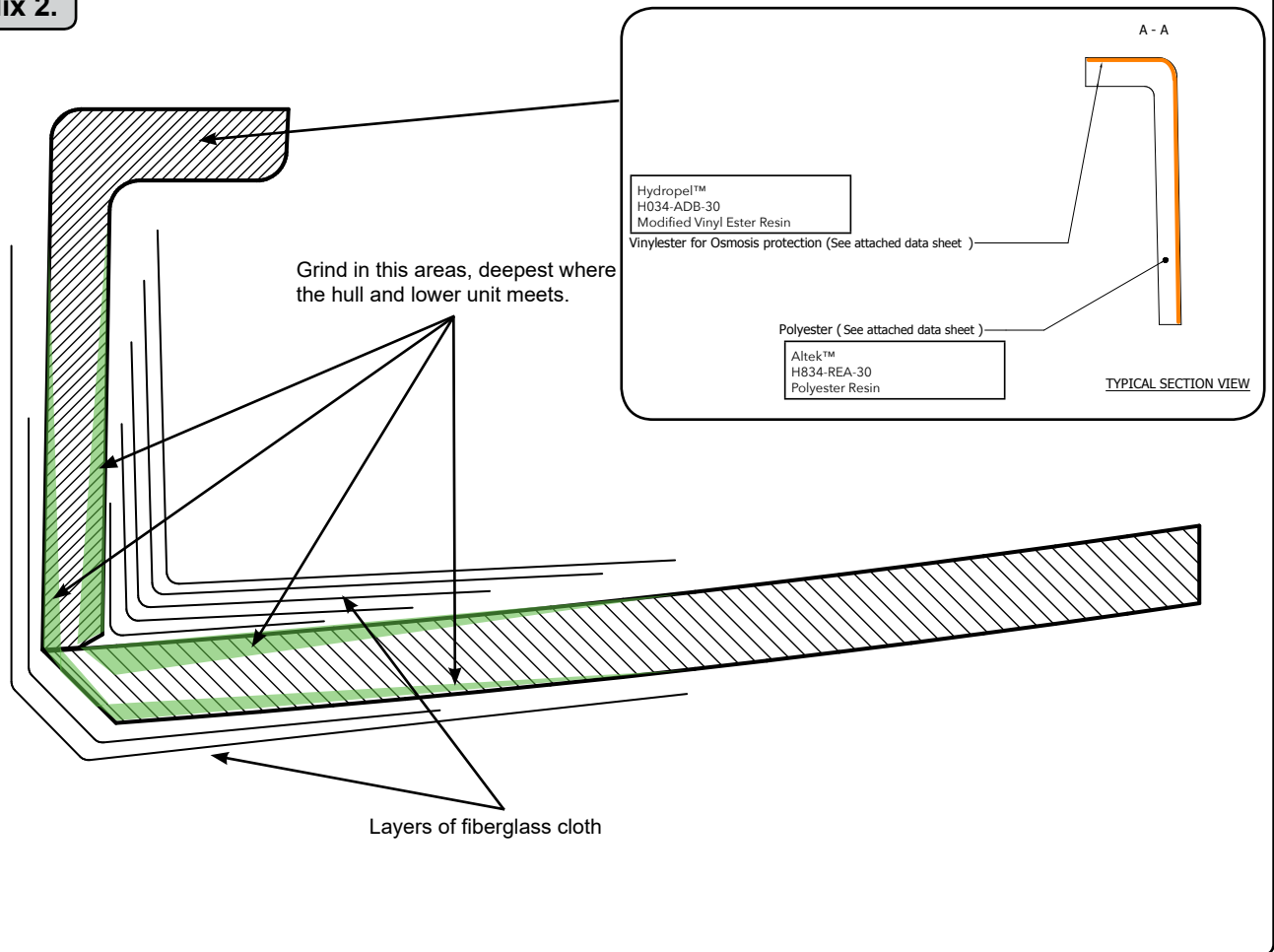

EN

General Moulding process

Start the laminating with a strong attachment point in each corner between the hull and the outside of the lower unit. Use epoxy and fiberglass cutting or similar, which laminating material is the actual boatbuilders responsibility. Cover the upper part if grinding is necessary. After moulding material have cured, run the retract mechanism down, disassemble the hatch and remove the upper part from the unit.

Laminate the inside and outside of the lower unit part solid to the hull. Use appropriate fiberglass cloth (which laminating material is the actual boatbuilders responsibility). Before grinding of hull and unit lower part, precautions must be taken against grinding dust inside the boat. Grind deepest where the hull and lower unit part meets.

Lamination/moulding **MUST** be done by qualified personell!

IMPORTANT!

Laminating the inside and outside of the lower unit part solid to the hull is very important.

IMPORTANT!

Usage of appropriate fiberglass/Vinylester/Polyester is the actual boatbuilders full responsibility and very important.

Appendix 3.

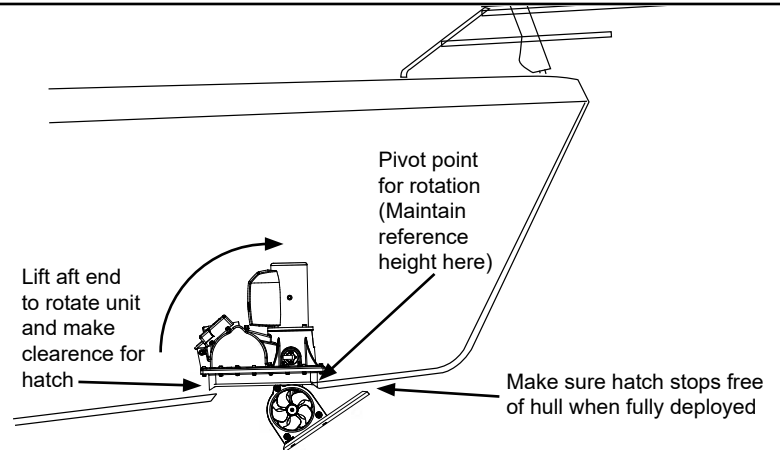
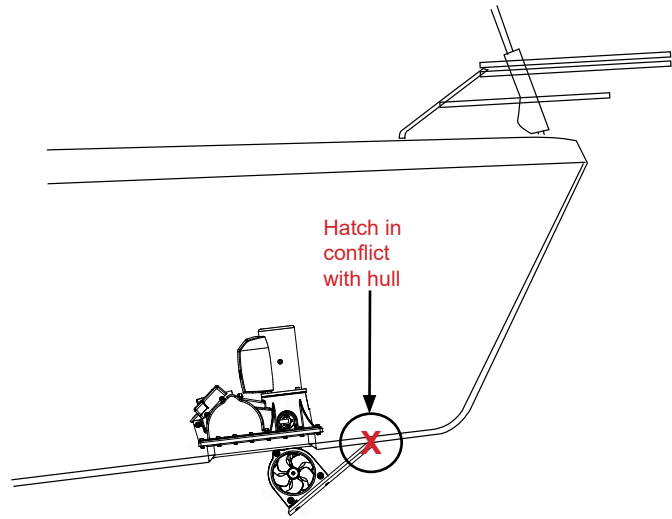
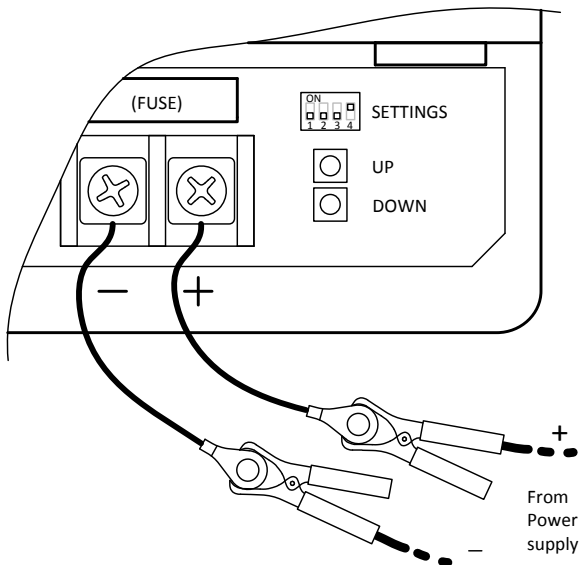

EN

Positioning the thruster - Checkpoints before moulding

- Assemble the upper part temporary to the lower part. Check that the upper part is oriented correct in relation to the lower part (fig 1). Use approx 6 bolts/nuts evenly distributed.

Do not use seal/sealant at this stage.

- Connect 12 or 24 DC temporarily (refer to the label on actuators for correct voltage) to the two short 6 mm² cables on the terminals on the controller. Set switch no. 4 on the DIP-switch marked "SETTINGS" to ON during the whole installation procedure. Press "DOWN" to run the retract mechanism down so that the hatch can be temporary attached. Adjust the hatch onto the 4 bolts using the nuts, and check the fit to the hull by adjusting the position of the unit at the same time as "UP" and "DOWN" keys are operated. The hatch should have a close fit along all 4 sides.

- Check that the hatch opens fully without touching the hull. If the hatch is obstructed by the hull, rotate the unit by lifting it in the aft end keeping the reference height in front - until the hatch clears the hull. Do not rotate the unit more than necessary, 2-3 degrees of rotation should be sufficient in most cases. The closed position of the hatch will be altered automatic by the load sense function when the unit is lifted in the aft end and the hatch must be angled to fit, turn the the rear bolts holding the hatch out to compensate.

Before the chamfered sides of the hull and hatch is sealed and filled, the hatch might protude to far into the hull. This is correct and will ensure that the hatch is functioning as end stop for the retract mechanism

If the hatch is not closing properly due to the actuators reaching their end stop, a wedge must be used in each corner between the lower part and the hull to increase the height so that the hatch is pressed into the hull opening.

NB! Retract is factory calibrated.
Calibration is only required if 150000 controller is replaced or position sensor is been loose or replaced.

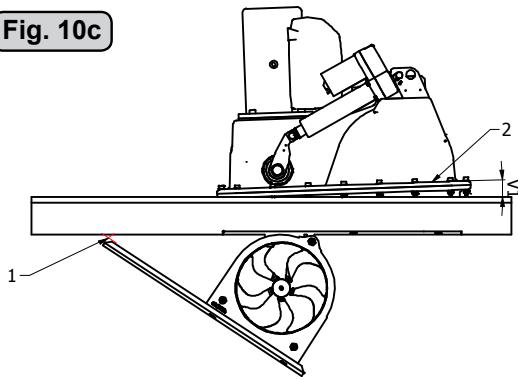
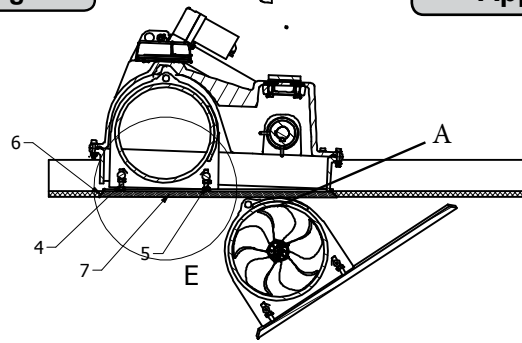
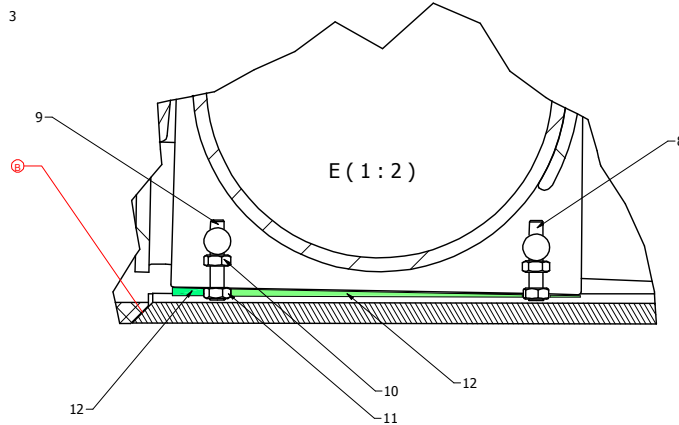
Fig. 10c**Fig. 10d****Appendix 4.****Fig. 10e**

EN Fitting the upper part & hatch

1. Conflict area (1) is located to the front of the hatch. Fig 10c
2. To avoid this conflict (1) the thruster flange (2) can be angled with an angle (V1) compared to the hull.
3. Adjust the level (6) of the hull plate (7) according to the hull with the adjustment bolts and nuts (8, 9, 10 and 11) between the hatch and the thruster hatch holding mechanism. As you see from the drawings the angle (V1) has to be adjusted by bolt (8) and (9), and locked with nut (10) to the bar and (11) to the hatch. Fig 10e
4. Make sure that the inside tunnel diameter is free from the hull (A) seen from the side of the thruster. Fig 10d.

13. After moulding in SRF flange is completed, the upper thruster case is ready to be installed.

Apply MS Polymer or equivalent on flange surface to seal and avoid water leakage. Ensure that glue is compatible with SRF and thruster case materials. This is the boatbuilder/installer full responsibility.

Fig. 14.

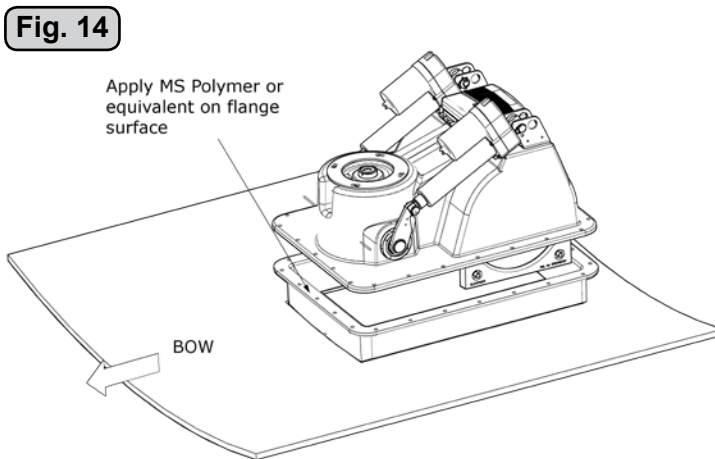

14. Secure the upper thruster case by tightening bolts to 4Nm/2,9lb/ft. Fig. 15.

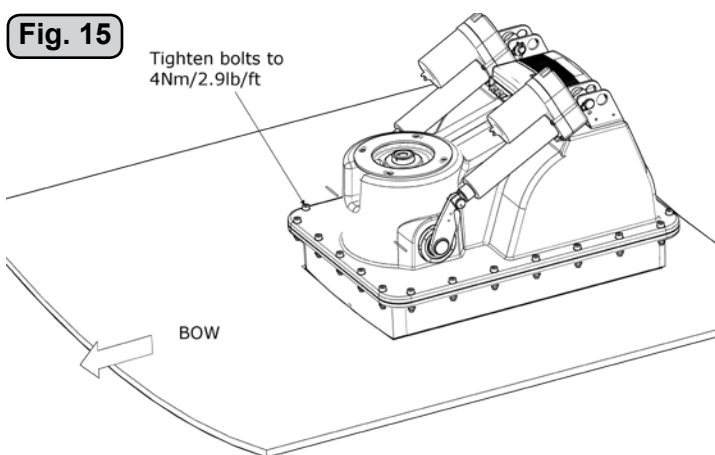

15. In order to get correct hole alignment/pattern to hatch do following steps:

- Fit custom made pin bolts to the tunnel rings. The ends of the bolts must be sharp in order to create marks in the hatch. The pin bolts must be in correct height so the hatch will fit in its inner position.
- Place hatch in its inner position, then press or tap with a hammer to create punch marks inside of hatch.

Fig. 16.

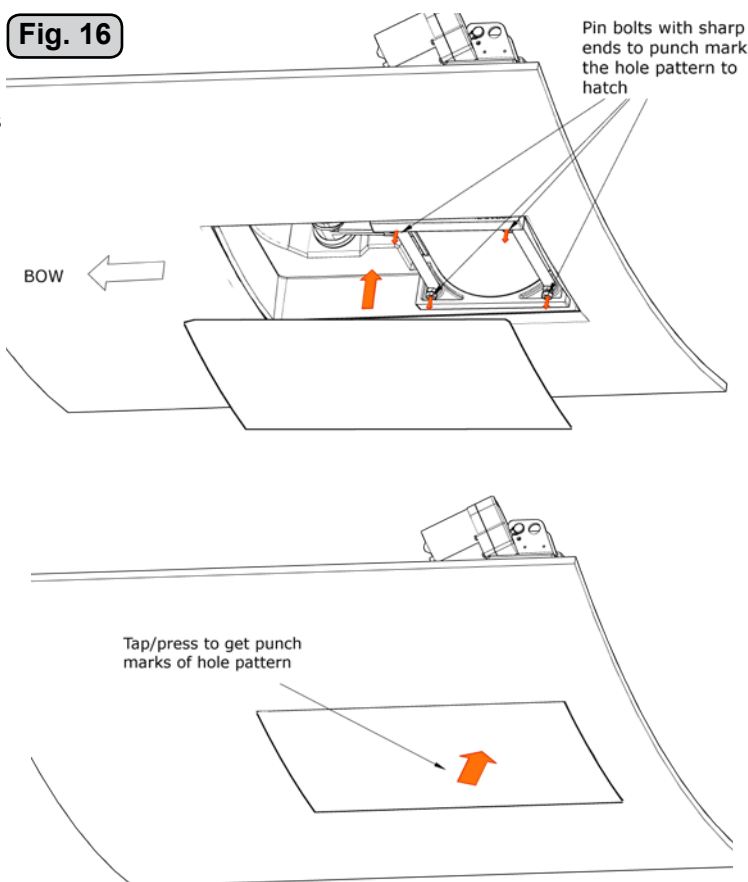

4 x pin bolts
Part#: Comming soon

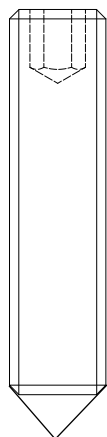

16. When hole pattern is achieved, drill holes corresponding the bolt dimensions.

Fig. 17

- Outside of hatch, holes must be countersink.

Important! Drill the holes in 90° to the hatch surface. Fig. 17.

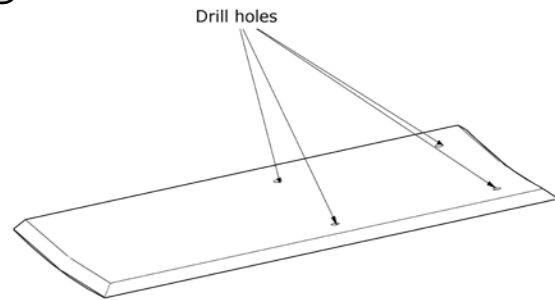

Drill holes

Inside of hatch

Countersink
all 4 holes

Outside of hatch

17. Temporary fit the hatch to the tunnel rings:

Fig. 18

- Ensure the bolts do NOT get in conflict with tunnel. Bolts might be cutted, depending on hull thickness. Fig. 18.

- Next process ist to fill the gap between hatch and hull edges.

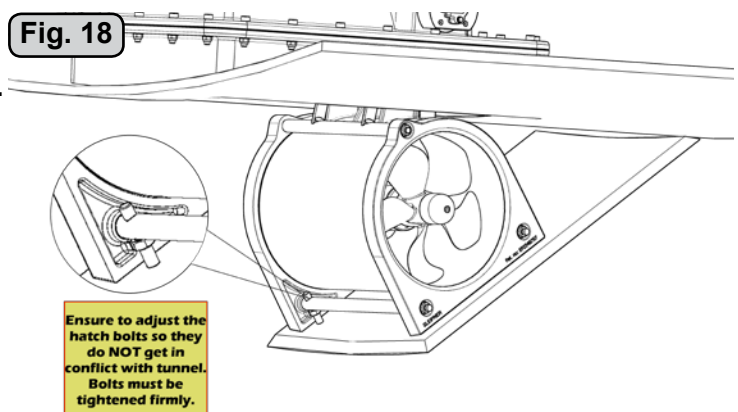

Ensure to adjust the hatch bolts so they do NOT get in conflict with tunnel. Bolts must be tightened firmly.

18. Apply a layer of aluminium or duct tape on hatch opening edges on the hull. See Fig. 19.

Fig. 19

- Apply Epoxy filler or equivalent on hatch edges and run the thruster to IN position. Fig. 19.

- When in inner position, smooth out filler and add more if needed. After curing time, grind and smoothen the surface.

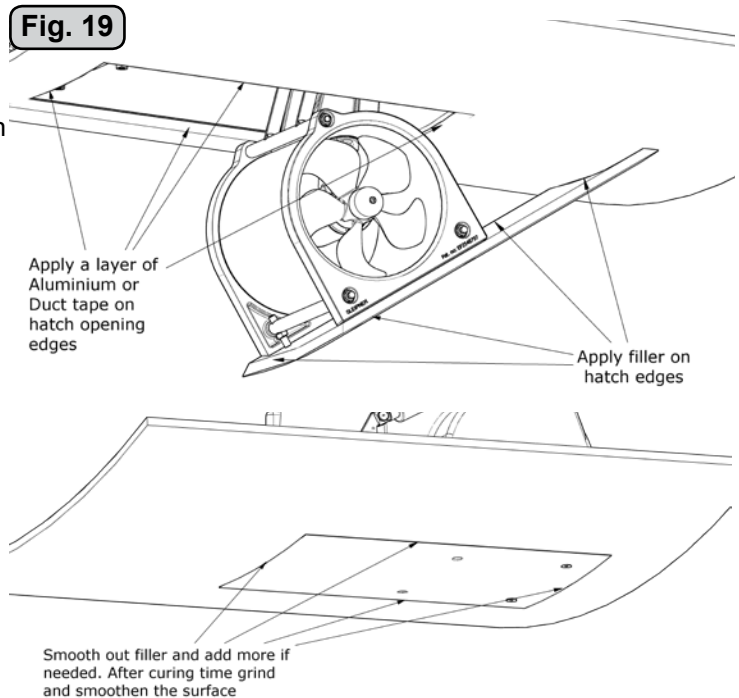

Apply a layer of Aluminium or Duct tape on hatch opening edges

Apply filler on hatch edges

Smooth out filler and add more if needed. After curing time grind and smoothen the surface

19. Unscrew and remove hatch to smoothen off excessive material before coating the hatch. See Fig. 20.

Fig. 20

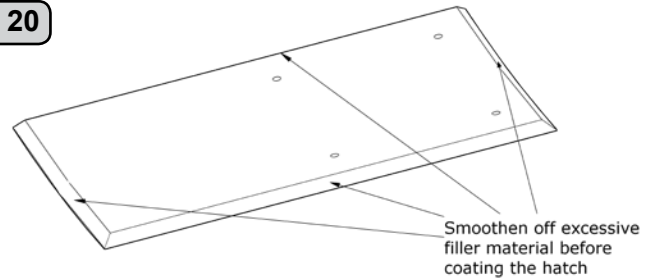

20. Now re-install hatch in its correct position

- Apply glue on to tunnel rings contact surface, so the hatch will be secured properly. See Fig. 21.

- Tighten bolts so hatch will fit properly.

- Apply coating inside and outside of hatch opening on hull.

Fig. 21

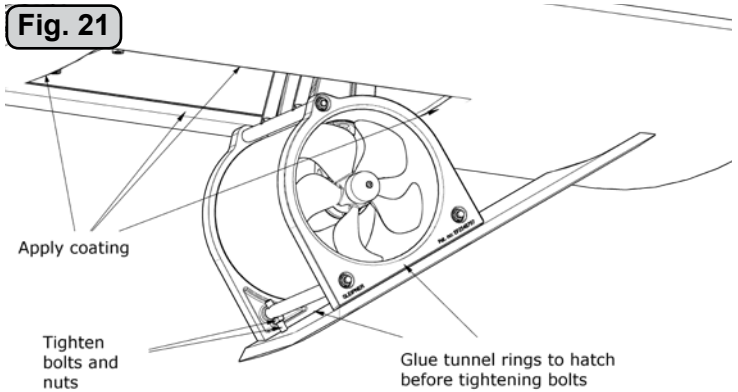

21. After completing the mechanical installation ensure to test the thruster mechanism with running the thruster IN and OUT to ensure following:

- **IMPORTANT!** The hatch vs hull **MUST** work as a mechanical end stop. Fig. 22.

- **IMPORTANT!** The front edge of the hatch **MUST** release easily (correct clearance) from the hull. Fig. 22.

IMPORTANT!

Any solutions regarding this matter must make sure that the hatch **STOP** into the hull so all the slamming forces from the water is absorbed by the hatch and the hull, and not the thruster mechanism.

Fig. 22

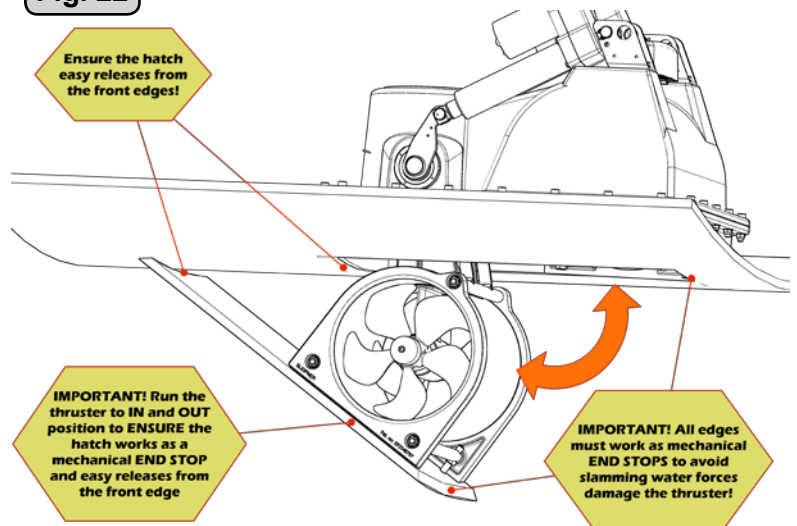

22. Now complete the electrical installation according to following sections in this manual.

IMPORTANT!

Remember to remove the red installation part, ref Fig 3 in step 2.

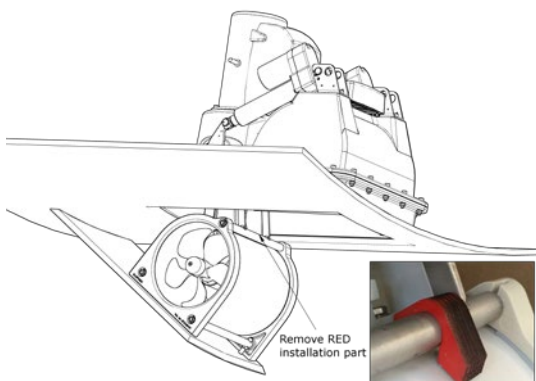

Fig. 23

Install the electro motor and other electronics according to electrical instructions in manual

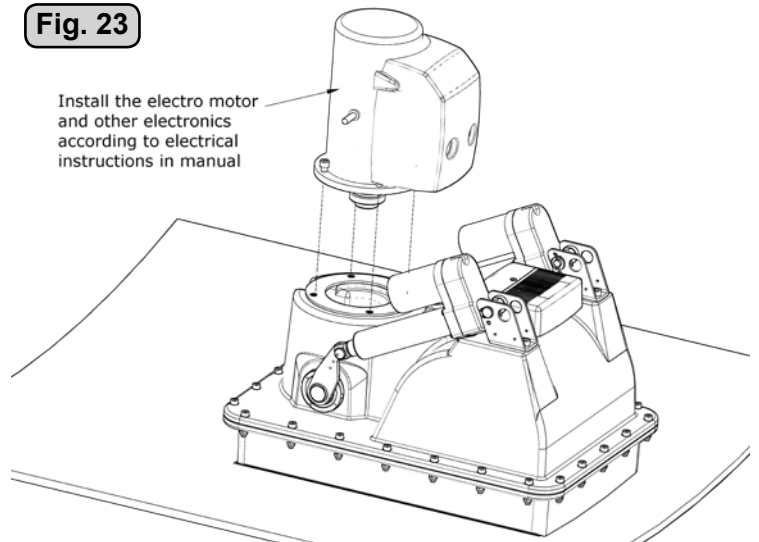
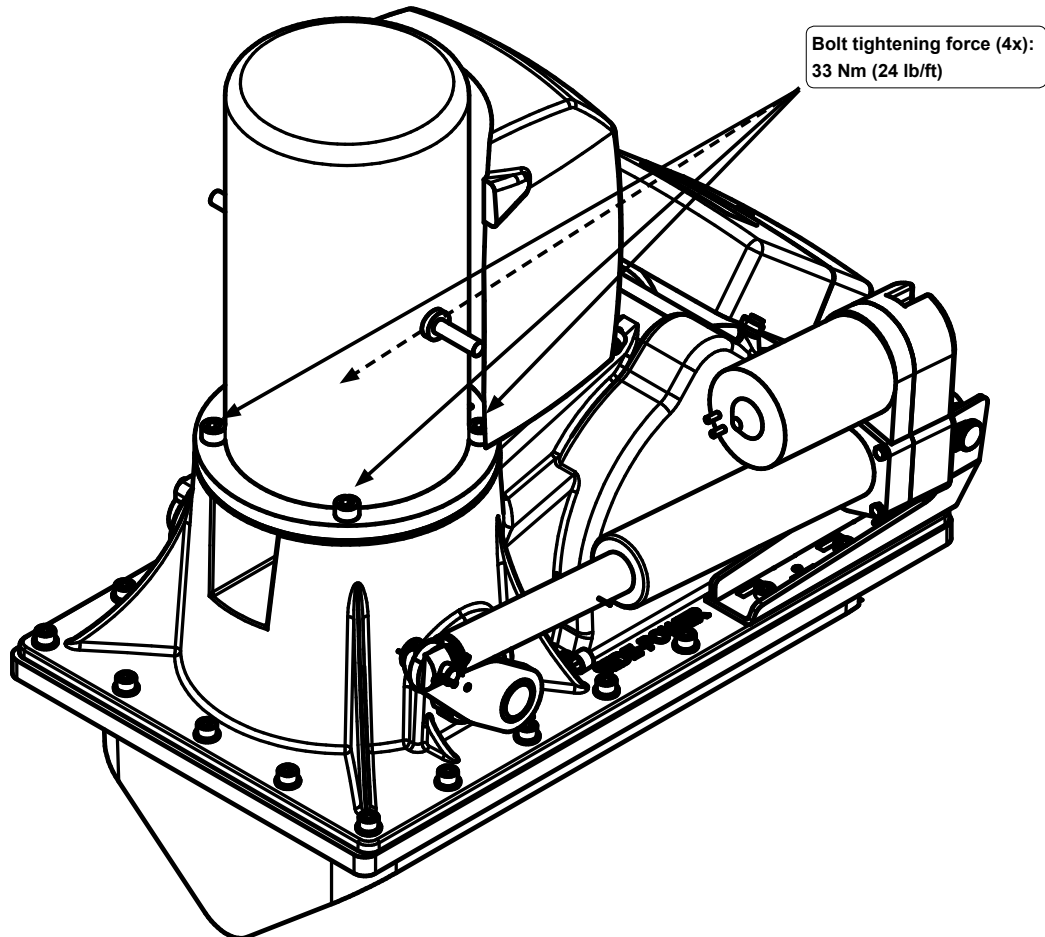

Fig. 24a



EN

Fitting the electromotor

1. Remove the 4 bolts in the motor bracket.
2. Place the motor gently on the motor bracket with motor solenoid facing control box. Ensure that key on axle and keyway in one-piece coupling are aligned.
3. Fasten the motor to the bracket with the 4 bolts, tighten to 33Nm (fig. 24).
4. Check the drive system by turning the propeller. Make sure that the drive shaft is completely deployed, i.e 90 degrees to the hull. It will be a little hard to turn (because of the gear reduction and the motor), but you should easily be able to turn it by hand.

NB! Paint the gearhouse and propeller with antifouling for propellers to prevent growth of barnacles or similar which would reduce the performance dramatically. Do not paint the propeller shaft, the anodes or the end face of the gearhouse.

NB! Do not run the thruster for more than very short bursts without being in the water.

NB! If the boat is still under construction when the electromotor is installed, it must be covered up to avoid dust from the building going into the motor and the solenoids. This cover must be removed before the thruster is being used.

IMPORTANT!

If the motor is mounted with the optional 90° gearbox, the motor must be supported as shown in fig. 24b to avoid stress in the gearbox.

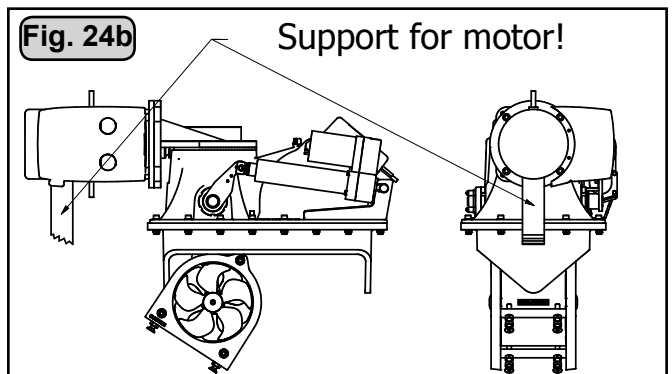
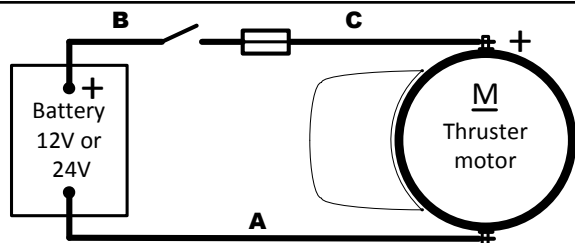

Fig. 25

SRV/SRL Models



SRVP/SRLP Models

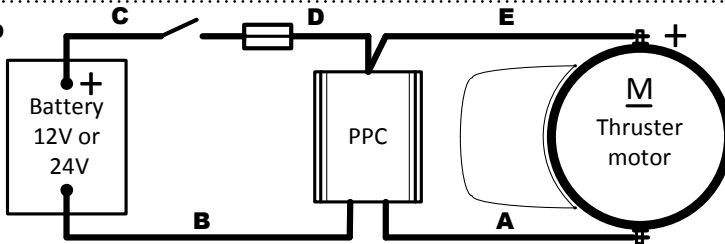
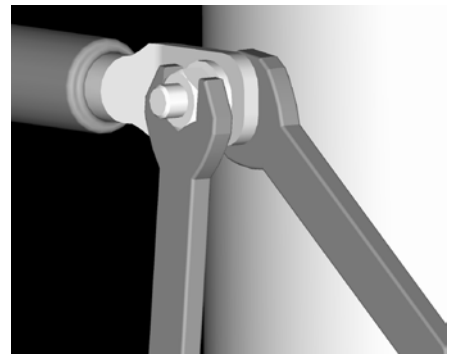

Fig. 26



Battery & cable recommendations:

Model	Voltage	Nominal current draw	Min. battery CCA		>7m total + & -		7-14m total + & -		15-21m total + & -		22-28m total + & -		28-35m total + & -		36-45m total + & -	
					Min.	Rec.	Min.	Rec.	Min.	Rec.	Min.	Rec.	Min.	Rec.	Min.	Rec.
SRV80/185T SRL80/185T	12 V	530 A	DIN: 550 SAE:1045	mm ² AWG	60 2/0	70 2/0	95 3/0	2x 70 2x 2/0	2x 70 2x 2/0	2x 95 2x 2/0	2x 95 2x 3/0	270*	2x 120 2x 4/0	340*	NA	NA
	24 V	260 A	DIN: 300 SAE: 570	mm ² AWG	25 1	35 1	35 1	50 1/0	60 2/0	70 2/0	70 2/0	95 3/0	95 3/0	120 4/0	120 4/0	2x 95 2x 3/0
SRV100/185T SRL100/185T	12 V	740 A	DIN: 750 SAE: 1425	mm ² AWG	95 3/0	95 3/0	2x 70 2x 2/0	2x 95 2x 3/0	2x 95 2x 3/0	280*	250*	375*	NA	NA	NA	NA
	24 V	340 A	DIN: 400 SAE: 760	mm ² AWG	35 1	50 1/0	50 1/0	70 2/0	60 2/0	95 3/0	95 3/0	120 4/0	120 4/0	2x 95 2x 3/0	2x 95 2x 3/0	2x 120 2x 4/0

Minimum and recommended cable dimensions can be identical due to safety margins and cable heat considerations for short cable lengths.



Electrical installation

- Explanation of electrical table
 - All cable lengths are the total of A+B+C(+D+E) in Fig. 25.
 - Battery size is stated as minimum cold crank capacity, not Ah.
 - Use slow fuse rated to hold stated Amp-Draw for min. 5 minutes.
- It is important that you use a good cable size and batteries with a high cranking capacity to feed the thruster, because it is the actual voltage at the motor while running the thruster that decides the output rpm of the motor and thereby the actual thrust. Please see the list below for advised min. sizes of cables and batteries. You can of course use larger cables for even better results.
- Connect the power supply to motor and controller according to diagrams VISUAL WIRING DIAGRAM for SRV/SRL or SRVP/SRLP version
- A main switch that can take the load without noticeable voltage drop must be installed in the main positive lead so the power for the thruster can be turned off independent of the rest when not on board or in emergencies. This should be placed in an easy accessible place and the boats instructions should inform that this should be turned off like the boat's other main switches.
- We also advice to install a fuse in the positive lead for protection against short circuiting of the main cables. This fuse should be of a adequate quality which normally means that it is physically large as these have less voltage drop than the simple / small ones. It should be of the slow type and sized to take the amperage draw for at least 5 minutes.
- It is highly recommended to install a **Sidepower Automatic Main Switch 897712 (12V) eller 897724 (24V)**. The AMS will be activated when the panel is turned on, contains an automatic short circuit fuse and a manual emergency stop. The AMS will also provide feedback to the panel regarding evt. faults.
- Connect power supply to the motor and controller according to schematics on pages 11 or 12 according to model.
- The cable ends must be fitted with terminals and these must be well isolated against contact with anything but the proper connection point.
- Terminals must be properly tightened. Secure/hold inner nut when tightening (Fig. 26). Tighten ø10mm / 3/8" bolt with 15 Nm/11lb/ft.



EN

Technical Specification 150000 Controller

Supply Voltage	7-31 VDC, Powered at B+ & B-
Power consumption	Less than 1.5 Watt in standby
Fuse @ 12V	40 Amp
Fuse @ 24V	40 Amp
Minimum Voltage at B+/B- for deployment	11.7 Volt for 12 Volt thruster 23.4 Volt for 24 Volt thruster
Operating temperature	-10°C to 60°C (14°F to 140°F)
Weight	500g/17,6oz

Technical wiring diagram, SRV/SRL models

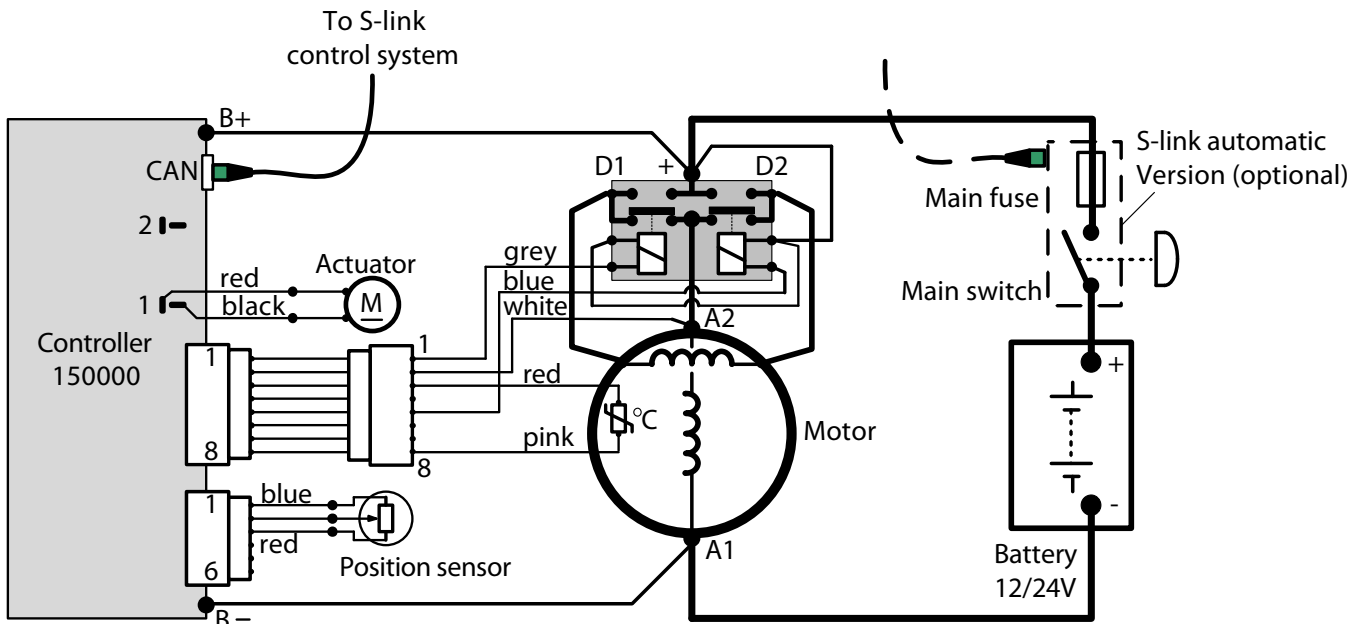

Visual wiring diagram, SRV/SRL models

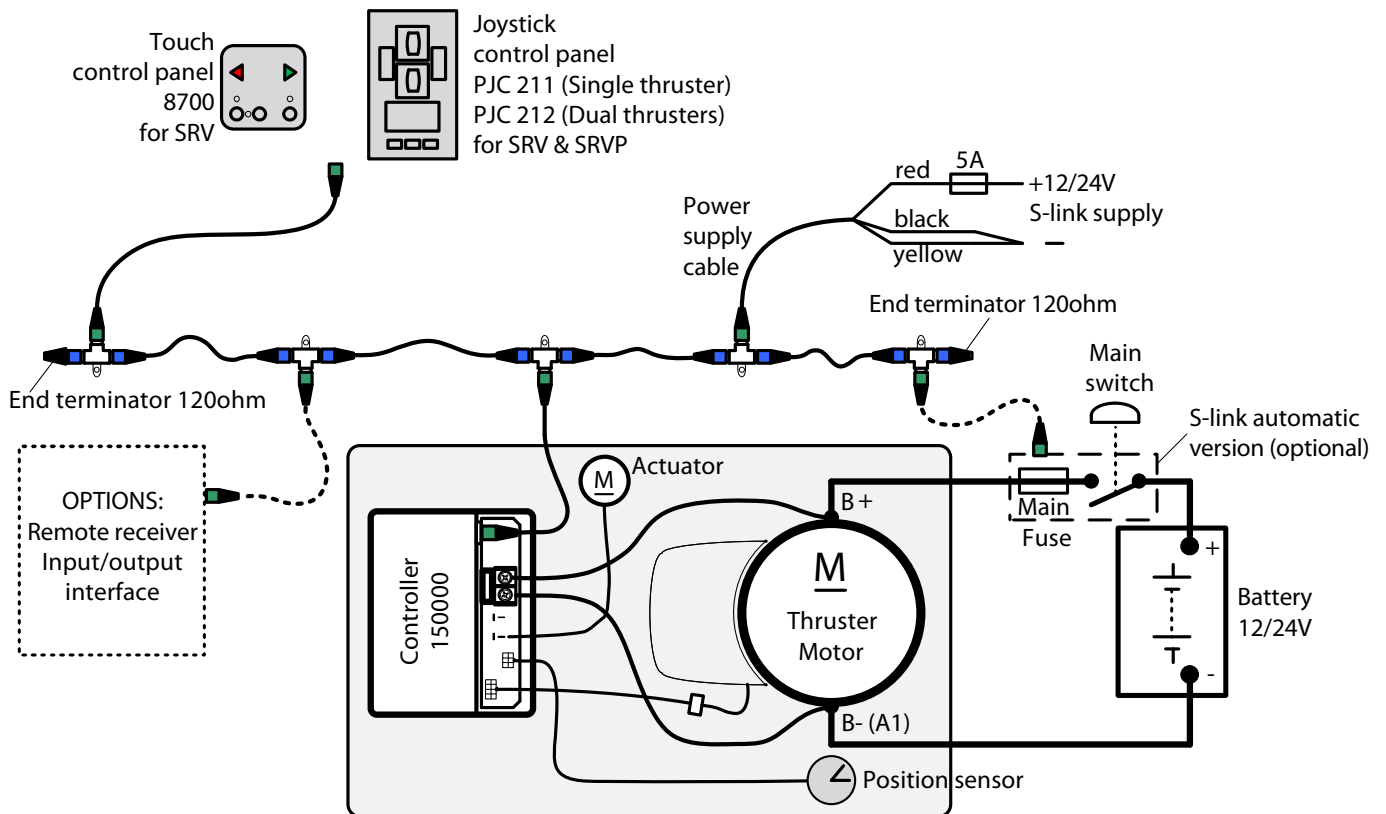

EN

S-link system schematics

The S-link control system is powered by a dedicated power cable connected to the system backbone as a normal spur cable.

The cable ends connect to battery pos. and battery neg. and the cable shield connects to battery neg.

The battery pos. must be connected through a 5A fuse.

Technical wiring diagram, SRVP/SRLP models

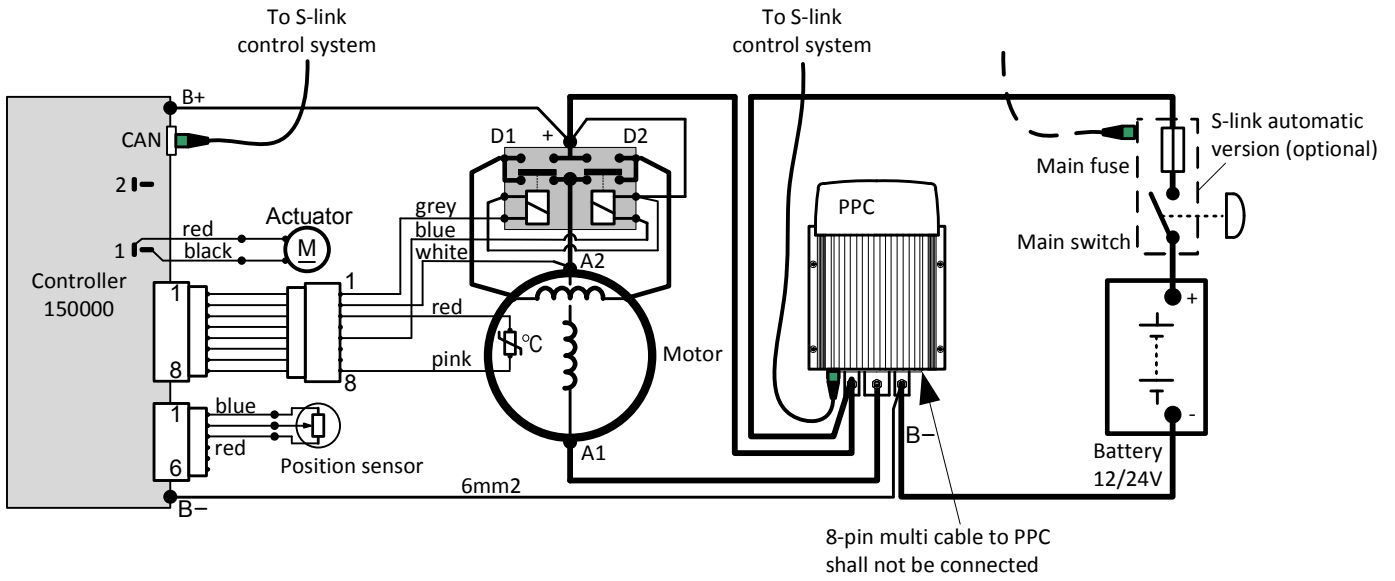

Visual wiring diagram, SRVP/SRLP models

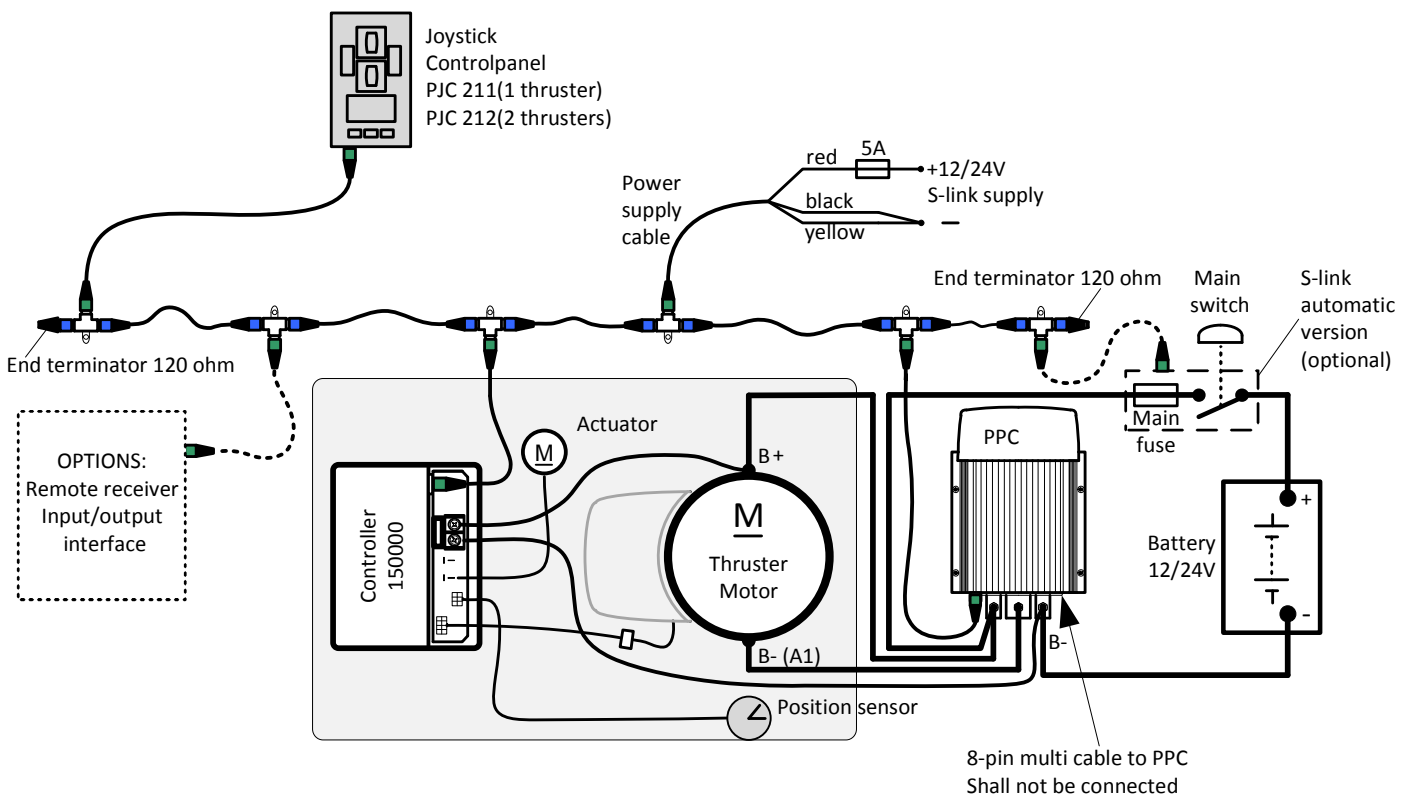
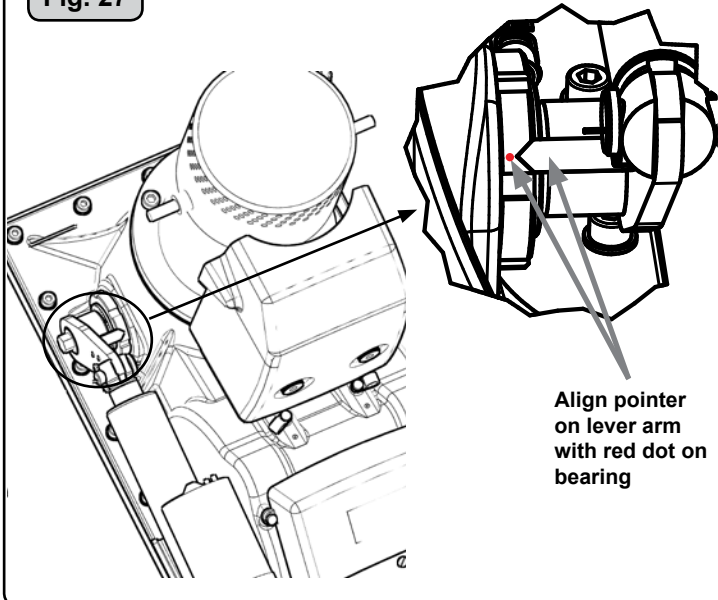
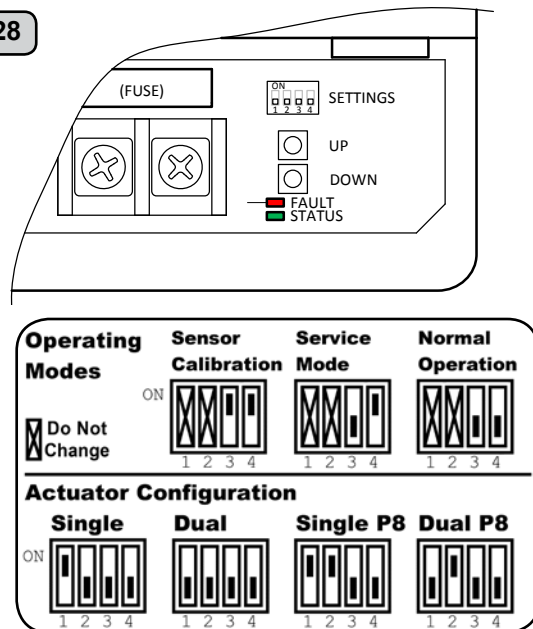

Fig. 27



Align pointer on lever arm with red dot on bearing

Fig. 28



EN

Check drive shaft alignment

IMPORTANT!

Before the thruster motor is run, the alignment of the drive shaft must be checked to be completely straight when it reaches its end position by operation from the control panel:

- Connect power to thruster and S-link system.
- Set DIP-switch on controller to 0000.
- Turn on panel. Drive shaft deploys.
- The actuator lever arm and the bearing have alignment marking (Fig 27).
- If the marks aligns, turn panel off. Drive shaft retracts.
- If the marks do not align, proceed to calibrate drive shaft.

EN

Calibrate drive shaft alignment

The drive shaft is correctly aligned when manufactured!

- 1: With dipperswitches select 'Service Mode'.
- 2: Align arrow on actuator arm with calibration mark, using UP/DOWN buttons.
- 3: With dipperswitches select 'Sensor Calibration Mode'.
- 4: Press and hold both UP and DOWN buttons until STATUS LED light up green.
If FAULT LED light up red, then the calibration is out of position (wrong align mark).
- 5: With dipperswitches select 'Operation Mode', thruster retracts.

EN

Actuator Configuration

Dipperswitch number 1 & 2 configures the actuator(s).

No.1 set to OFF when the retract has two actuators.

No.1 set to ON when the retract only has one actuator.

No.2 set to OFF when the retract does not have P8 type actuator(s).

No.2 set to ON when the retract has the P8 type actuator(s).

If dipperswitch no.2 is set to ON and the actuator gives an rattling noise when the door closes, then there probably is not P8 actuator(s) and dipperswitch no.2 needs to be set to OFF.

The actuator is an P8 type:

-If the actuator has an plastic cap at the back where you can adjust the actuator manually.

-If it is marked with an sticker with P8

-If the manufacturer label says P8

EN

LED indication

Continuous red light:

Motor overtemp, Controller overtemp, Controller no communication, Motor relay failure
Low battery voltage, Position sensor failure, No power to actuators, Retractable unit failure, Temp sensor open circuit.

Flashing red light:

Red light fast blinking: Dipperswitch in invalid position.

Red light short flash every 2 seconds: Shaft not calibrated, or shaft calibrated out of range.

Continuous green light:

Normal mode, Service mode (actuators operated by UP/DOWN buttons).

Re-calibrated "down"-position.

Flashing green light:

No S-Link communication.

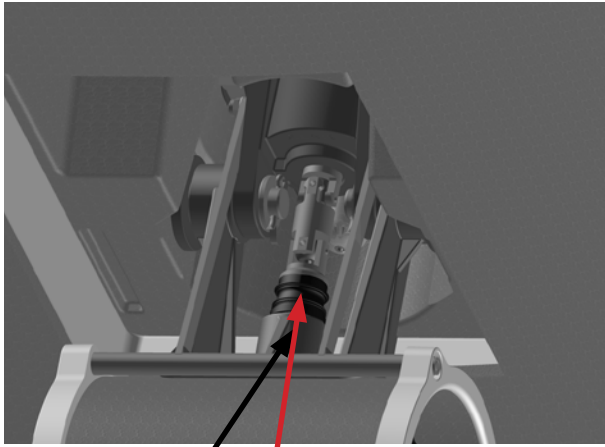

Check and relubricate with waterproof grease if necessary

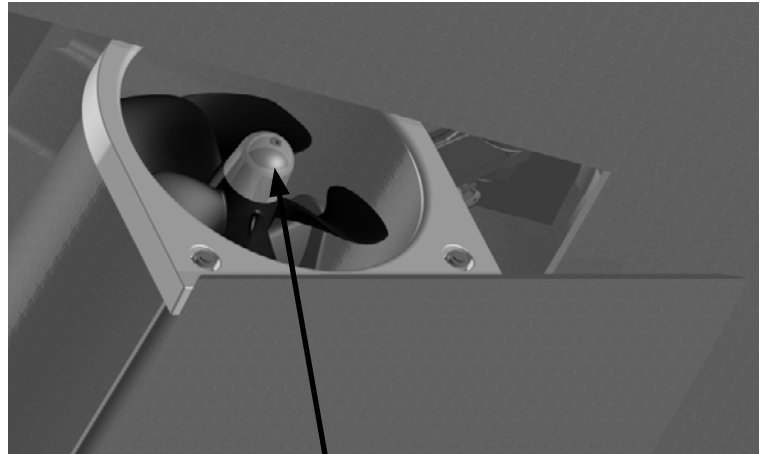

Anode, gearleg

DO NOT apply anti-fouling or clean with any kind of chemicals in this area. Only clean with water.

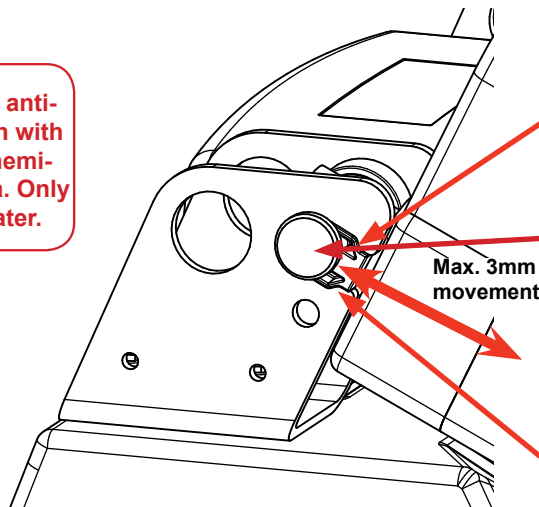

Check for wear in this area

Max. 3mm movement

Part no. 140117 will be worn and must be replaced!

Check for wear in this area

EN

Maintenance

» Keep the propeller and gearhouse clean from growth by painting with antifouling before every season.

PS! The anodes, seals and propeller shafts must absolutely not be painted. Be careful to not get paint in the "tracks" in the gearhouse that the propeller hub moves in or on the threads for the propeller nut

» Change the anodes before every season, or when about half the anode is gone. Always use a sealant on the screw holding the anode to ensure that it does not fall off.

» As a part of the seasonal service of your boat, and before every season, always check that:

- The propeller is securely fastened
- The bolts holding the electric motor to the motor bracket are fastened correctly.
- The drive shaft in the retract mechanism is lubricated
- The area where the thruster is installed is clean and dry. If there are signs of water you must try to find the source and eliminate it.
- All electrical connections are clean and fastened firmly.
- Make sure that your batteries are in a good condition so that the thruster gets a good voltage. Old or bad batteries will give a reduced performance from the thruster.

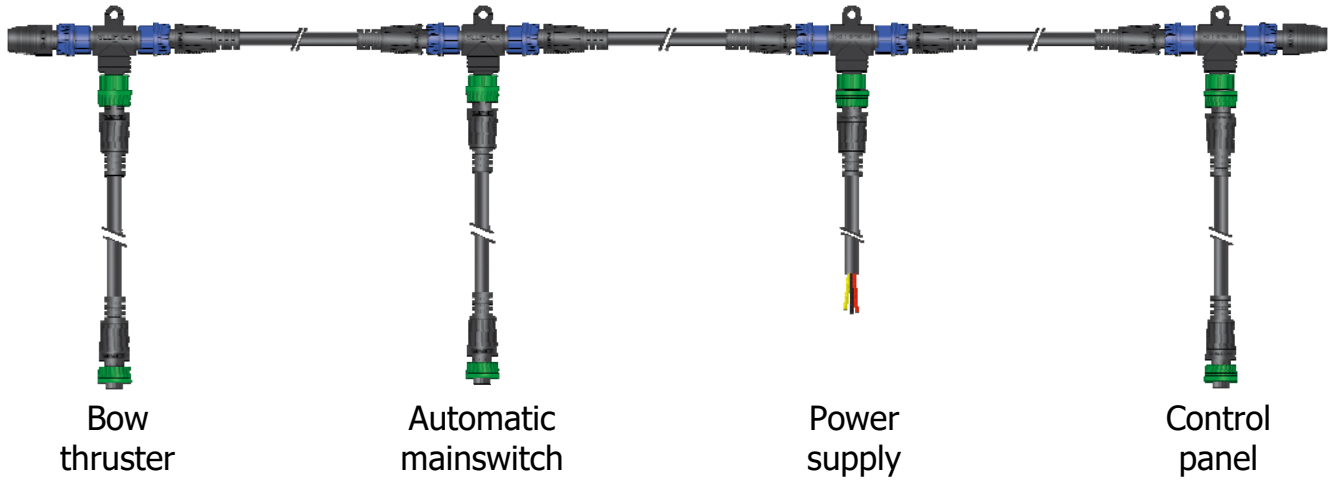

S-link system overview

S-link is a "CAN" based control system with full intelligent communication between all units in the system, much like a computer network.

Main advantages include:

- Round, compact and waterproof plugs with unique keying and color coding to avoid faulty hookup
- Unlimited number of commands or information transfer on a single cable
- Proprietary Sleipner commands, but built 100% on NMEA 2000 standard

BACKBONE cables

Forms the main "loop" around the boat.

Part #: 6 1320-xxM (xx=length)

- 6 1320-0,2M (0,2m)
- 6 1320-2M (2,0m)
- 6 1320-4M (4,0m)
- 6 1320-7M (7,0m)
- 6 1320-15M (15,0m)
- 6 1320-20M (20,0m)



BACKBONE kabler

Danner "hovedsløyfen" rundt i båten.

Art. nr: 6 1320-xxM (xx=lengde)

- 6 1320-0,2M (0,2m)
- 6 1320-2M (2,0m)
- 6 1320-4M (4,0m)
- 6 1320-7M (7,0m)
- 6 1320-15M (15,0m)
- 6 1320-20M (20,0m)

SPUR cables

Must be used to connect all parts to the backbone cable (one for each component, no exceptions), recommended to be as short as practically possible.

Part #: 6 1321-xxM (xx=length)

- 6 1321-0,4M (0,4m)
- 6 1321-1M (1,0m)
- 6 1321-3M (3,0m)
- 6 1321-5M (5,0m)



SPUR kabler

Må benyttes for å koble alle komponentene til backbone-kabelen (en for hver komponent, uten unntak), anbefalt å ha så korte lengder som mulig.

Art. nr: 6 1321-xxM (xx=length)

- 6 1321-0,4M (0,4m)
- 6 1321-1M (1,0m)
- 6 1321-3M (3,0m)
- 6 1321-5M (5,0m)

POWER cable

Must be one in each system, length 2.5m

Part #: 6 1328



POWER kabel

Må være en i hvert system, lengde 2.5m

Art. nr: 6 1328

T-CONNECTOR

Must be one for each spur, including power cable

Part #: 6 1326

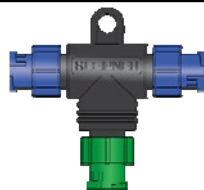

T-CONNECTOR

Må benyttes for hver spur-kabel, inkludert Power-kabel

Art. nr: 6 1326

BACKBONE EXTENDER

Connects two backbone cables to extend length

Part #: 6 1322



BACKBONE EXTENDER

Kobler sammen to backbone-kabler for å øke lengden

Art. nr: 6 1322

END TERMINATOR

Must be one in each end of the backbone "loop"

Part #: 6 1327



END TERMINATOR

Må benyttes i hver ende av backbone-"hovedsløyfen"

Art. nr: 6 1327



Example of the control wiring with S-link system for boats with one control position and one retractable thruster.

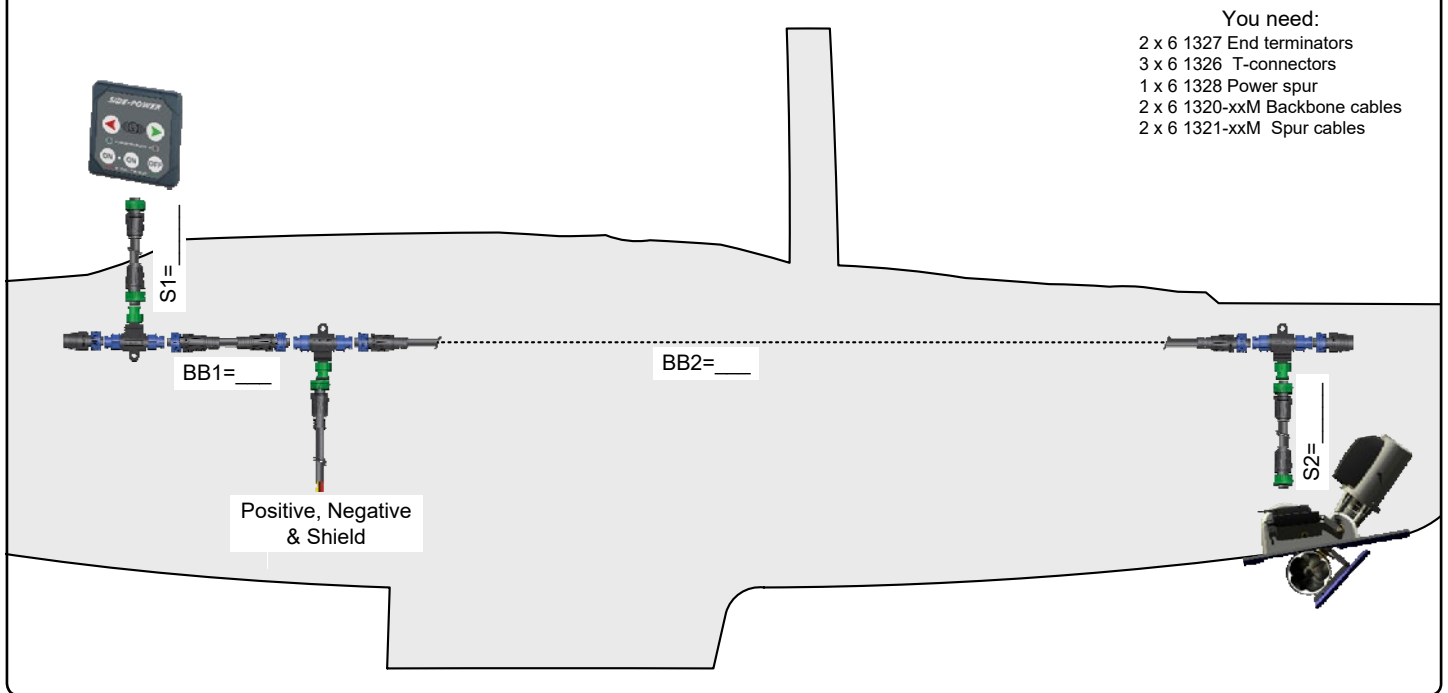

EN

S-link planning & precautions

Routing the Backbone:

Plan routing of the backbone so that length of spur cables will be kept at a minimum.

Avoid routing the S-link cables close to equipment that might cause interference to the S-link signals, such as radio transmitter equipment, antennas, high voltage cables etc.

The backbone MUST be terminated in each end with the 6 1327 End Terminator.

Spur cables:

Spur cables can be left unterminated (i.e. routing can be prepared for future additional equipment), make sure to protect open connectors from water and moisture to avoid corrosion in connector .



EN

Control panels

PANEL ON: push both “ON” buttons simultaneously, thruster deploys.

PANEL OFF: push “OFF” button, thruster retracts.

For a detailed description of status and alarm messages shown, please refer to the manual included with the control panel.

Status and alarms includes:

Overtemperature, power supply, motor and solenoid, communication, retract mechanism

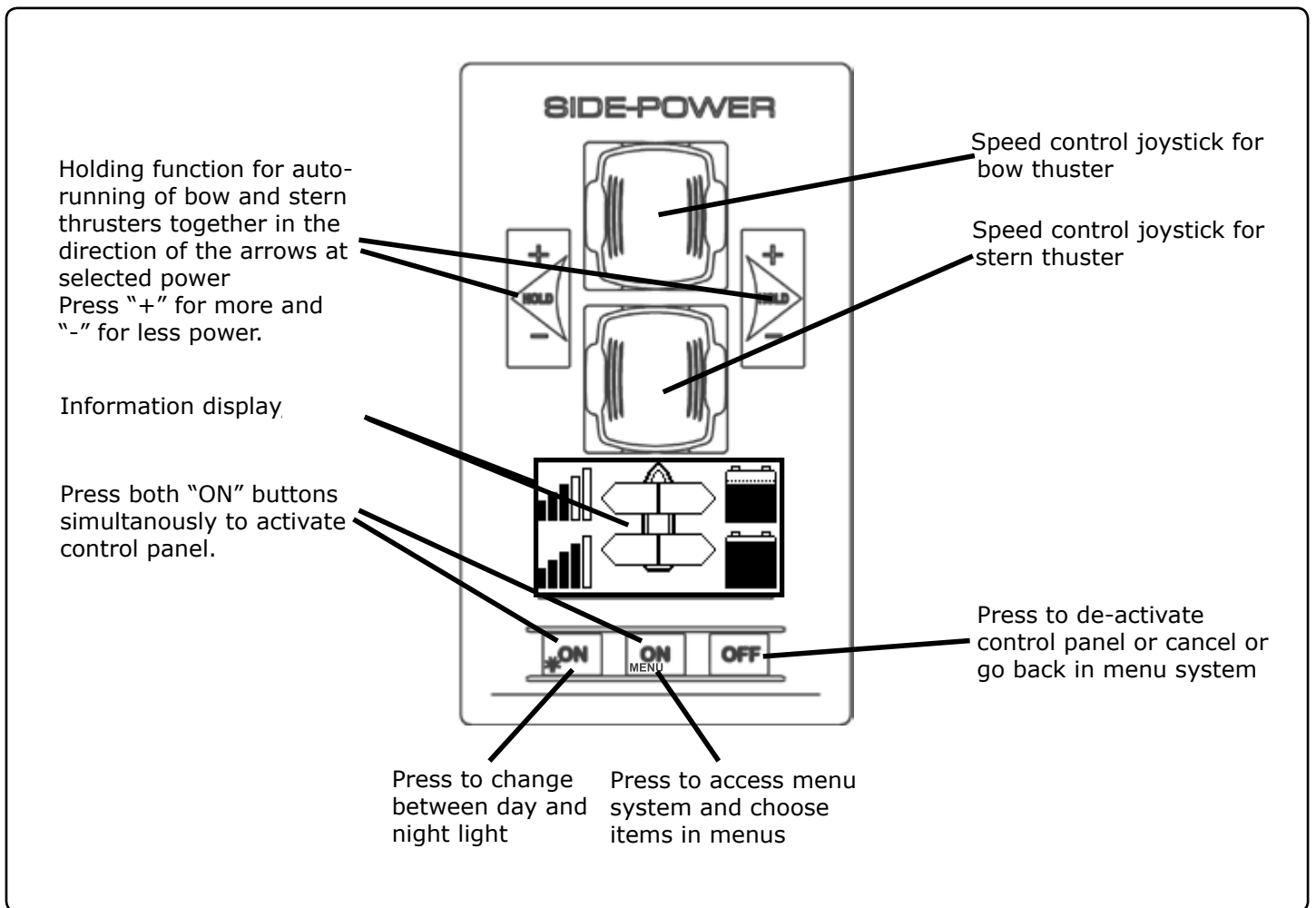

EN

How to use Side-Power thrusters

How to use a bowthruster

1. Turn main power switch for the bow thruster on. (Always turn off the main power switch when not on board.) A Side-Power Automatic Main Switch will turn on/off when the panel is turned on/off.
2. Please take some time to exercise thruster usage in open water to avoid damages to your boat.
3. Turn the control panel on by pushing both "ON" buttons on the original Side-Power panel simultaneously.
4. Move the joystick in the direction you wish the bow to move. Other controls like foot switches or toggle-switches on the throttle can be used. These are connected to the S-link control system by a S-link interface (Refer to schematics in interface manual for installation)
5. Depending on the sideways speed of the bow, you must disengage the control device shortly before the bow is in the desired direction, as the boat will continue to move after stopping the bow thruster.

How to use a single stern thruster

Some boats might however have installed a single stern thruster because of space limitation in the bow. In this case the stern thruster is used in the same way as a single bow thruster or moving the boat's stern.

How to use a bow and stern thruster combined

The combination of a bow and stern thruster offers total manoeuvrability to the boat and the opportunity to move the bow and the stern separately from each other. This enables you to move the boat sideways in both directions and to turn the boat around its own axis staying at the same place. Refer to the PCJ control panel manual for detailed instructions.

- Again, if in doubt, try in open water first!

- Propeller is fastened correctly to the shaft.
- Propeller turns freely in tunnel.
- The zinc-anode holding screw is tightened well with thread glue.
- Anti-fouling have been applied to the gearhouse and propeller but NOT on the zincanode or the gearhouse lid where the propeller is fastened.
- The brush springs are fitted correctly on the brushes in the electro-motor (check through the grid around the top end of the motor).
- Correct drive direction as per controlpanel.
- All electrical connections are clean, dry and tight, and the correct cable, fuse and main switch sizes have been installed.
- With a ohm meter check that there is no electrical connection between electromotor body and positive terminal on the motor and between the electromotor body and the negative (A1) terminal on the motor.
- The bolts holding the electromotor to its bracket are tightened correctly.
- Check that the driveshaft is completely straight, i.e 90 degrees to the hull, before initial run of thruster. Ref. page 14

The thruster has been installed as per the instructions in this manual and all points in checklist above have been controlled.

Signed: Date:.....

Extra pre-delivery tests by installer/yard who does not use other quality control systems !

Thruster type: Voltage:

Serial number: Date of delivery:

Correct drive direction as per control panel:

Voltage at thruster when running:

Battery cable size used:

The compartment where the thruster is fitted is isolated from general bilge water and has no obvious or suspected risks for flooding.

Other comments by installer:

- Ensure that you know the location of the main battery switch that disconnects the thruster from all power sources (batteries) so that the thruster can be turned off in case of a malfunction.
- Always turn the main power switch off before touching any part of the thruster, as an incidental start while touching moving parts can cause serious injuries.
- Always turn the control device off when the thruster is not in use.
- The maximum continuous usage time of the electrical thruster is approximately 3 minutes. The electromotor has a built in thermal cut-off switch that will shut off the electromotor if it is overheating and re-engage it when it has cooled down some. This should be considered when planning your maneuvering.
- This also means that the thruster will limit its total running time per time period so that you can not count on the thruster to hold you in a current and side wind for extensive time periods. Depending on the surrounding temperatures etc. the thruster will be able to run approximately 10 % of the time.
- Never use a thruster close to somebody in the water, as the thruster will draw objects close by into the tunnel and contact with the rotating propellers will cause serious injuries.
- With the boat on land, only run the thruster for a fraction of a second, as without resistance it will accelerate very fast to a damaging rpm. Also, while the thruster is in air, make sure that the propellers have come to a complete stop before performing a directions change of the thruster, as it might cause damage to the thruster.
- If the thruster stops giving thrust while the electromotor is running, chances are that there is a problem in the drive-system. You must then immediately stop trying to run it, and turn it off, as running the electromotor for more than a few seconds without resistance from the propeller, can cause serious damage to the electromotor.
- When leaving the boat always turn off the main power switch for the thruster.
- We advise to always keep the main engine(s) running while using a thruster. This will keep the batteries in a good charge condition. This will also give better performance to the thruster, as a higher voltage at the thruster results in a higher torque (power) in the electromotor.
- Please note that the performance of a thruster strongly depends on the voltage available at the electromotor. This voltage will decrease by time because aging batteries have a reduction of capacity. By installing new batteries the effect of the thruster should be back at the original level.
- Make sure that only one control is used at the same time, if two panels are operated in opposite directions at the same time the thruster will not run at all. If they are operated in the same direction the thruster will run in this direction.
- If the thruster is not performing or functioning as usual, the cause for this must be found and corrected as soon as possible so to avoid causing any other or further damage to the equipment. You must also turn off the main battery switch immediately in case the problem is of electric origin.
- Never store anything (e.g. equipment, sails, ropes etc.) in the same compartment as the thruster. When the thruster runs for a longer period it will get hot and will cause damage.
- It is the owner/captain/other responsible party full responsibility to assess the risk of any unexpected incidents on the vessel. If the thruster stops giving thrust for some reason while maneuvering you must have considered a plan on how to avoid damage to persons or other objects.

Before seeking assistance at the help desk of your Side-Power dealer/distributor please perform these tests and make notes of all measurements to ensure that they have as much information as possible to work on. Some error messages and alarms will be shown in the panel display. Please refer to the control panel manual.

NB! All check points and solutions must be carried out after consulting the relevant information elsewhere in this manual to understand how the system is intended to work. If you are unable to understand what to check, you must consult a professional.

Check	Solution
Not able to turn panel on with the ON-buttons	Check S-link power supply
No reaction when operating the panel	A system scan must be executed. Refer to control panel manual
» The thruster motor is running, but there is no thrust.	
The flexible coupling between motor and driveshaft or the propeller drive pin might have been damaged.	The SR(P)130 og SR(P)170 models have a flexible coupling that can fail. The coupling is visible on the underside of the motor from inside the boat. Run motor and observe the coupling. Replace coupling if necessary. If it is required to turn the drive shaft by hand, deploy the thruster as normal by turning the control panel on, wait until the thruster stops in deployed position and turn the battery switch off. Remove the fan cover on the motor to be able to turn it.
Is the propeller properly attached to the propeller shaft and is the drive pin in place.	Attach or replace propeller and/or drive pin
Can the drive shaft be turned by hand with the electro motor removed.	If the gear leg is damaged, it is recommended to replace the complete unit - not attempt to repair internal gears and bearings.
» The thruster does not start at all or works only in one direction.	
Refer to the control panel manual for detailed explanations of warning and error codes shown on panel display/LEDs.	
» The thruster has an unexpected low performance.	
Check voltage at thruster battery when running.	If less than 10,5 V / 21V the thruster will not perform at specified effect.
Check that all the brush-springs sits correctly on the brushes in the electromotor.	If one or more brushes are loose/has no tension from the brush-spring, the performance will be low.
Check that the propeller, gearhouse and tunnel is free from growth/barnacles etc.	If there is growth in the tunnel, this will disturb/block the waterflow and especially barnacles on the propeller will greatly reduce performance.

1. The equipment manufactured by Sleipner Motor AS (The "Warrantor") is warranted to be free from defects in workmanship and materials under normal use and service.
2. This Warranty is in effect for of two years (Leisure Use) or one year (Commercial use) from the date of purchase by the user. Proof of purchase must be included, to establish that it is inside the warranty period.
3. This Warranty is transferable and covers the product for the specified time period.
4. In case any part of the equipment proves to be defective, other than those parts excluded in paragraph 5 below, the owner should do the following:
 - (a) Prepare a detailed written statement of the nature and circumstances of the defect, to the best of the Owner's knowledge, including the date of purchase, the place of purchase, the name and address of the installer, and the Purchaser's name, address and telephone number;
 - (b) The Owner should return the defective part or unit along with the statement referenced in the preceding paragraph to the warrantor, Sleipner Motor AS or an authorized Service Centre, postage/shipping prepaid and at the expense of the Purchaser;
 - (c) If upon the Warrantor's or Authorized Service Centre's examination, the defect is determined to result from defective material or workmanship, the equipment will be repaired or replaced at the Warrantor's option without charge, and returned to the Purchaser at the Warrantor's expense;
 - (d) no refund of the purchase price will be granted to the Purchaser, unless the Warrantor is unable to remedy the defect after having a reasonable number of opportunities to do so. Prior to refund of the purchase price, Purchaser must submit a statement in writing from a professional boating equipment supplier that the installation instructions of the Installation and Operation Manual have been complied with and that the defect remains;
 - (e) warranty service shall be performed only by the Warrantor, or an authorized Service Centre, and any attempt to remedy the defect by anyone else shall render this warranty void.
5. There shall be no warranty for defects or damages caused by faulty installation or hook-up, abuse or misuse of the equipment including exposure to excessive heat, salt or fresh water spray, or water immersion except for equipment specifically designed as waterproof.
6. No other express warranty is hereby given and there are no warranties which extend beyond those described in section 4 above. This Warranty is expressly in lieu of any other expressed or implied warranties, including any implied warranty of merchantability, fitness for the ordinary purposes for which such goods are used, or fitness for a particular purpose, and any other obligations on the part of the Warrantor or its employees and representatives.
7. There shall be no responsibility or liability whatsoever on the part of the Warrantor or its employees and representatives for injury to any person or persons, or damage to property, loss of income or profit, or any other consequential or resulting damage or cost which may be claimed to have been incurred through the use or sale of the equipment, including any possible failure or malfunction of the equipment, or part thereof.
8. The Warrantor assumes no liability for incidental or consequential damages of any kind including damages arising from collision with other vessels or objects.
9. This warranty gives you specific legal rights, and you may also have other rights which vary from country to country.

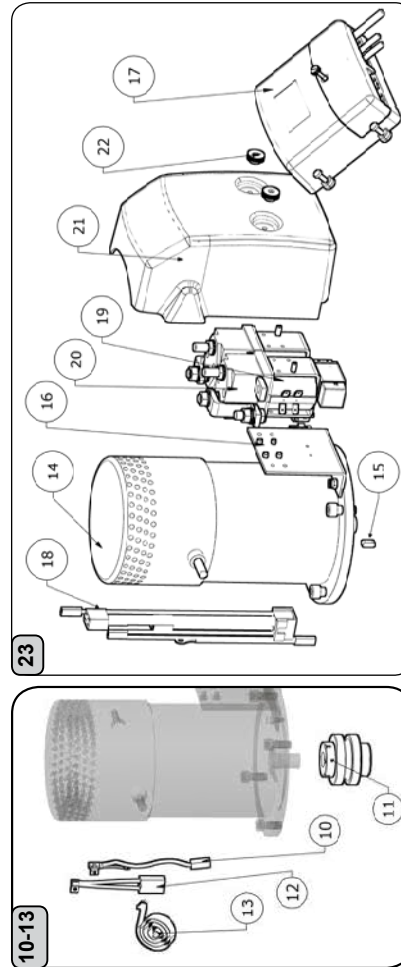
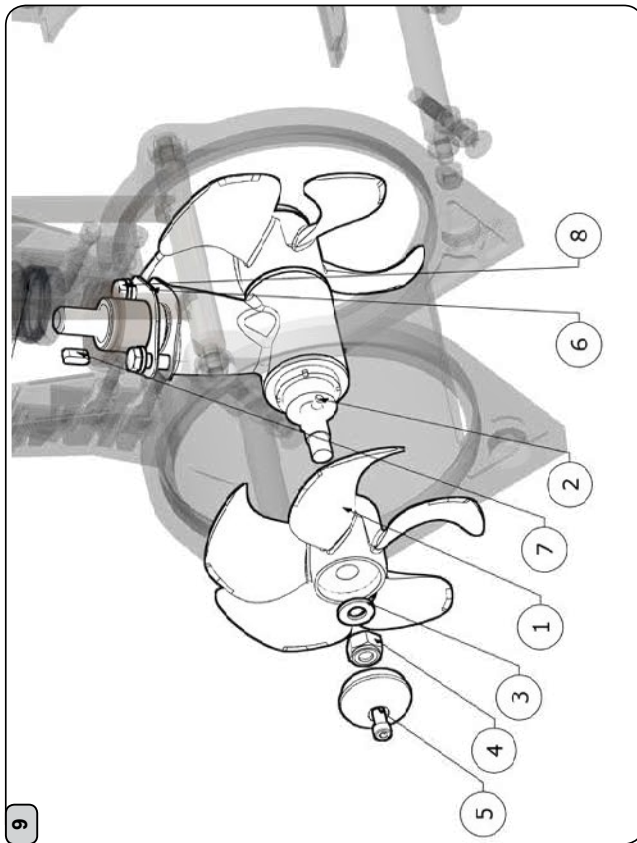

Model - year <	SRV(L)(P) 80/185T		SRV(L)(P) 100/185T		Pcs
	12V	24V	12V	24V	
23	6 0110 12	6 0110 24	8 0117 12	8 0117 24	
22	Nut for solenoid cover 6 8810				
21	Solenoid Cover 6 2025				
20	6 0131 12	6 0131 24	6 0133 12	6 0133 24	
19	4 1372 12	4 1372 24	10 1371	4 1372 24	
18	Internal wiring loom 6 1222				
17	Electronic control box 150000				
16	Solenoid bracket kit 6 0135		10 0135 24		
15	Key for electric motor shaft 10 1440				
14	Electric motor N/A				
13	**	**	**	**	**
12	**	**	**	**	**
11	Complete flexible coupling 7 1462				
10	3 10 19	3 10 19	3 10 20	3 10 20	
9	Complete gearleg 8 0601*				
8	Gearleg bolt* 12830*				
7	Driveshaft key 6 1440				
6	Gasket 8 0610				
5	Zink anode 7 1190 A				
4	Locknut 4 1260				
3	Propeller washer 7 1181				
2	Propeller drivepin 6 1241				
1	Propeller 7 1261				

*** Please provide thruster serial number when ordering Temp sensor
 ** Please provide thruster serial number when ordering brushes and brush springs
 * Gear leg bolt 12830 must be used on SRV/L.

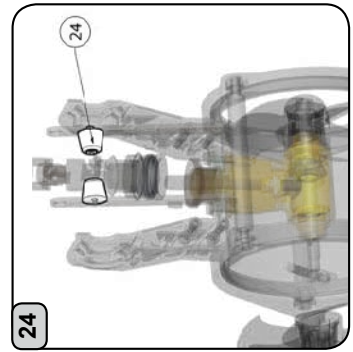
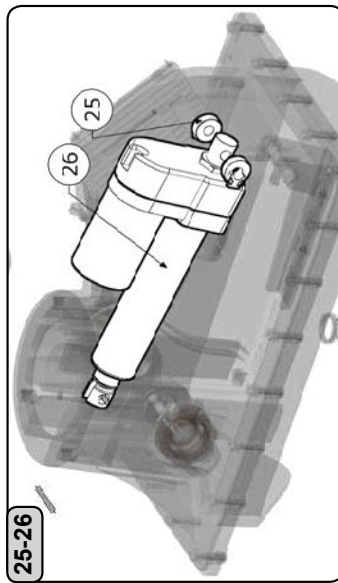
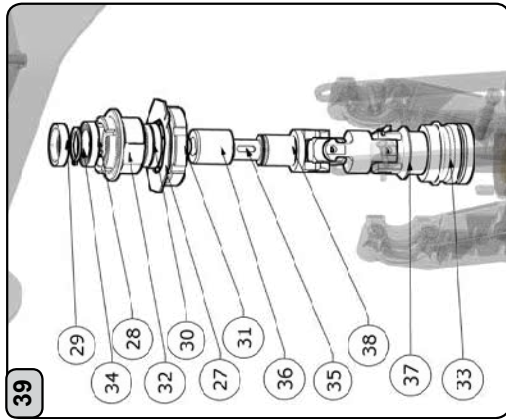

Model - year <	SRV(L)(P) 80/185T		SRV(L)(P) 100/185T		Pos
	12V	24V	12V	24V	
39	Complete SRV shaft/joint				
38	Joint part				1
37	Joint part sealed side				1
36	Brass part				1
35	Wedge				1
34	Segring				1
33	Sealant kit				1
32	Bearing				1
31	Lock nut				1
30	Johnson wedge				1
29	Sim ring				1
28	Bearing				1
27	Lock part				1
26	140000-P8	139999-P8	140000-P8	139999-P8	
	140117				
25	Aktuator security washer				
24	6 1180				

*** Please provide thruster serial number when ordering Temp sensor

** Please provide thruster serial number when ordering brushes and brush springs

* Gear leg bolt 12830 must be used on SRV/L.

SRV(L)(P)80-100

Partslist - SRV(P)80/185T - SRL(P)80/185T - SRV(P)100/185T - SRL(P)100/185T

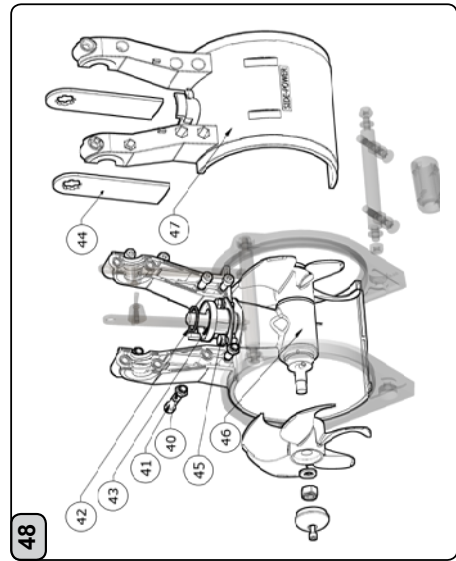
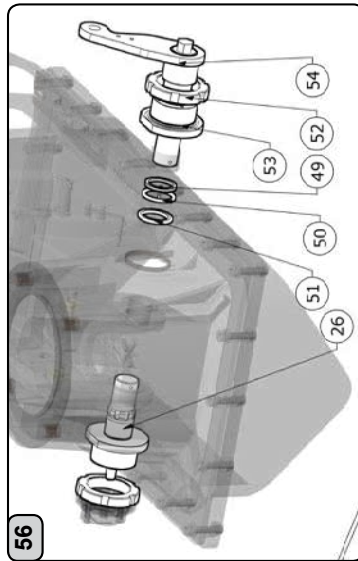
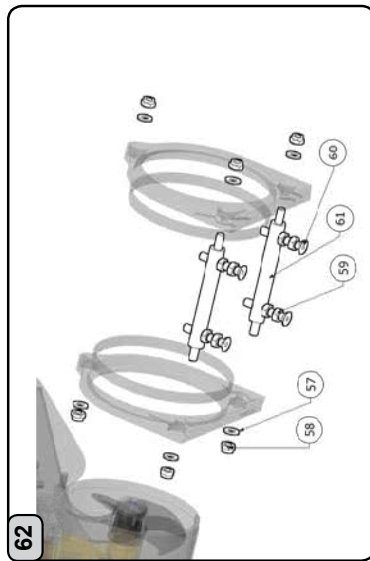

Model - year <	SRV(L)(P) 80/185T		SRV(L)(P) 100/185T		Pcs
	12V	24V	12V	24V	
62 Retract ring support kit	6 2142				
61 Connecting rod	140162				2
60 Bolt M10x70	11070				4
59 Plain nut	201000				8
58 Lock nut	74116				6
57 Plain washer	210125				6
56 Complete shaft kit					
55 Shaft sensor	140183				1
54 Shaft lift	140180				1
53 Brass bushing	140340				2
52 Brass ring	140341				2
51 O ring w/sealant	140192				2
50 O ring	6 2138				2
49 Turn ring	6 2139				2
48 Complete tunnel w/gearleg					
47 Tunnel	140158				1
46 Complete gear leg*	8 0601				1
45 Gearleg bolt*	12830				2
44 Lift plate	140164				2
43 Sealing holder	140174				1
42 O ring	140191				1
41 Bolts	10850				8
40 Nuts	3 1250				8

*** Please provide thruster serial number when ordering Temp sensor

** Please provide thruster serial number when ordering brushes and brush springs

* Gear leg bolt 12830 must be used on SRV/L.

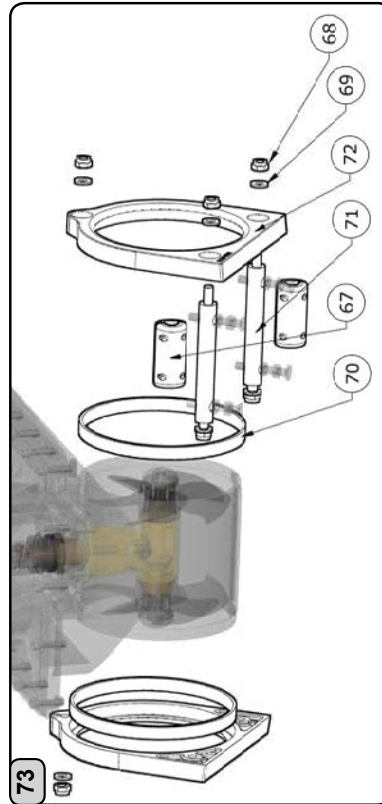
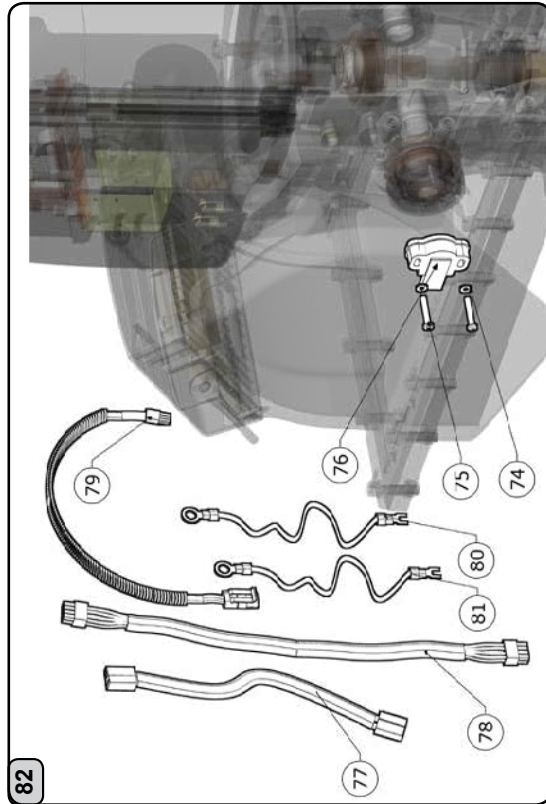

Model - year <	SRV(L)(P) 80/185T		SRV(L)(P) 100/185T		Pcs
	12V	24V	12V	24V	
85 Complete SRV 80/100 splint kit					
84		113005			5
83		20333			5
82 Electronic wiring and sensor kit					
81 - cable		150062			1
80 + cable		150063			1
79 Sensor cable		150064			1
78 Motor cable		150057			1
77 Actuator cable		150050			1
76 Sensor		140144			1
75 Bolt		10432			2
74 Washer		204125			2
73 Retract side cover kit					
72 Cover		140159			2
71 Connecting rod		140162			2
70 Guild ties		140184			2
69 Washer		210125			6
68 Nuts		201000			6
67 Anode rod		140629			2
66 O ring kit SRV 80/100					
65		140192			2
64		6 2138			2
63		6 2139			2

*** Please provide thruster serial number when ordering Temp sensor
 ** Please provide thruster serial number when ordering brushes and brush springs
 * Gear leg bolt 12830 must be used on SRV/L.



Sailtec GmbH
Hasselbinnen 28
D-22869 Schenefeld

+49 (0)40-822 994 0
info@sailtec.de
www.sailtec.de



Sailtec GmbH
Hasselbinnen 28
D-22869 Schenefeld

+49 (0)40-822 994 0
info@sailtec.de
www.sailtec.de



Sailtec GmbH
Hasselbinnen 28
D-22869 Schenefeld

+49 (0)40-822 994 0
info@sailtec.de
www.sailtec.de

Worldwide sales and service



www.side-power.com



Sailtec GmbH
Hasselbinnen 28
D-22869 Schenefeld

+49 (0)40-822 994 0
info@sailtec.de
www.sailtec.de



SLEIPNER MOTOR • AS P.O. Box 519 • N-1612 Fredrikstad • Norway
Tel: +47 69 30 00 60 • Fax: +47 69 30 00 70 • www.side-power.com • sidepower@sleipner.no