

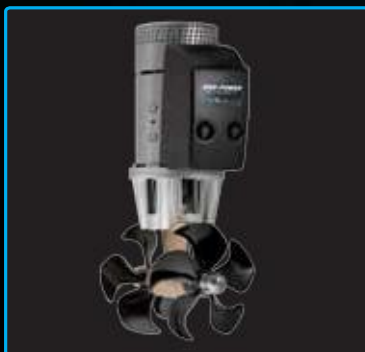

SAILTEC Projekt GmbH
Hasselbinnen 28
D-22969 Schenefeld

+49 40 822994-0
info@sailtec.eu
www.sailtec.eu



CONFIDENCE BY CONTROL

DC Thrusters



SIDE-POWER
Thruster Systems





Confidence by control





SIDE-POWER

Thruster Systems

by Sleipner Motor

Over 100 years of service

2008 marked Sleipner Motor's 100th year serving the boating community. While our product development focuses on making boating easier, safer, more accessible comfortable, our historic commitment has always been to offer the highest quality and reliability to our customers. Over the years we have grown to be the global leader in thrusters (with well over 100,000 put into service) and we are proud to know that our products have enhanced the boating experience for so many people.

It makes docking easy

As marinas get more crowded and slips become tighter, docking a boat safely is more challenging than ever before. Thrusters give you total control of your boat and allow you to maneuver into and out of tight spots with ease and actual control of your boat. Thrusters also have the benefit over "pod" systems with single joystick that they only need to apply a reasonable amount of power in the actual direction you wish to move the boat, instead of having to use perhaps as much as ten times this power through vectoring several thrust sources to achieve a net power in the desired direction, thereby avoiding the annoying wash for all the boats around you.

Confidence in all conditions

Boating is meant to be fun. Why end your day or week on the water with a stressful experience? A Side-Power thruster offers the help you need to be in full control when docking and departing regardless of wind conditions and currents. And you can do this with full confidence, you do not need to rely on a computer to understand what you mean to do and then re-apply this into other commands to several propulsion sources. Using thrusters means you control exactly what is going to happen.

Even simpler shorthanded boating

With the new DC Speed control thrusters, the unique "Hold" function takes shorthanded boating to a new level. See page 8 for more information

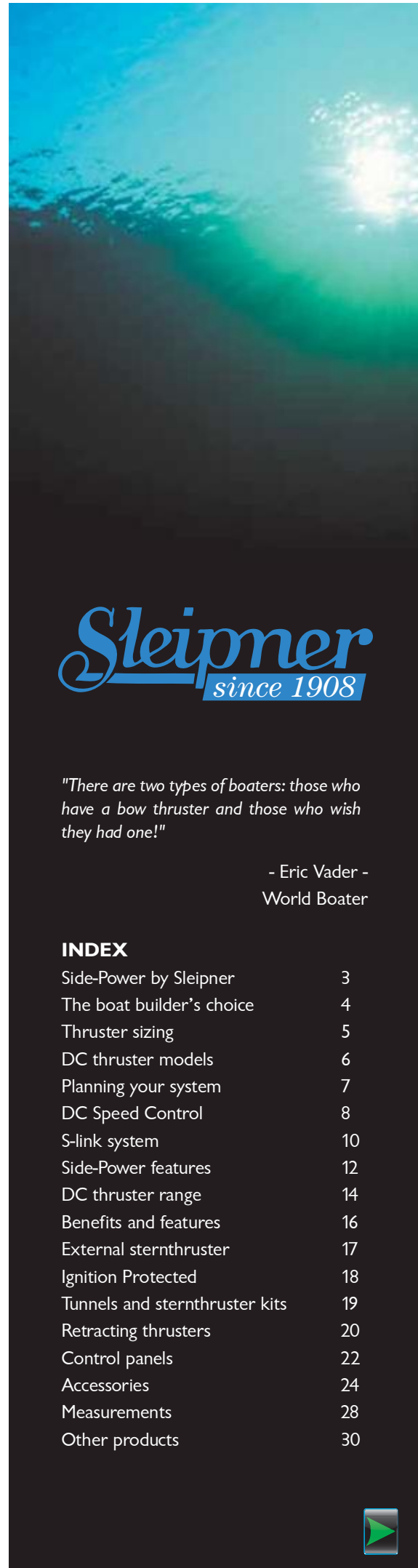

Sleipner
since 1908

"There are two types of boaters: those who have a bow thruster and those who wish they had one!"

- Eric Vader -
World Boater

INDEX

Side-Power by Sleipner	3
The boat builder's choice	4
Thruster sizing	5
DC thruster models	6
Planning your system	7
DC Speed Control	8
S-link system	10
Side-Power features	12
DC thruster range	14
Benefits and features	16
External sternthruster	17
Ignition Protected	18
Tunnels and sternthruster kits	19
Retracting thrusters	20
Control panels	22
Accessories	24
Measurements	28
Other products	30



The boat builders choice

Leading boat builders all over the world choose Side-Power for performance, reliability, ease of installation and unrivalled safety features. This commitment to quality and product development has made the Side-Power range of thrusters the benchmark in the industry.

Performance

The high performance of a Side-Power thruster is a result of our continuous efforts in product development and testing.

- propulsion technology know-how
- lightweight composite propellers
- purpose-built high power electric motors
- streamlined gearhouse design

Installation

Based on our experience and cooperation with major boatbuilders we have designed our systems to ensure it is easy to install a Side-Power thruster correctly.

- compact-sized units
- "Plug & Go" electric wiring
- easily accessible battery cable terminals
- easy installation of control panels
- fast and safe propeller mounting with locknut
- professional and solid GRP/composite stern thruster kits
- easy access zinc anodes
- easy fit sealed gearlegs

Safety & Reliability

The safety of the boat and those on board is our utmost priority. All Side-Power thrusters include standard features that protect against operator errors and technical problems, minimizing potential consequences. Side-Power thrusters are purpose built for professional use with no compromise on quality.

- overheat protection of electric motor
- mechanical protection of drive gear
- self-locking "high pressure" contacts
- extra wear and heat protection of internal wires
- non conductive and self extinguishing solenoid covers
- control panels have child safe On/Off (instant On) and automatic deactivation timed from last use
- in-house manufacturing, assembly and quality control
- 2-year limited warranty



Thruster sizing

By definition, any thruster will to some extent do a job in any boat. The key is to ensure that the chosen thruster will do the job you want it to in your boat. This is one of two main factors deciding the right thruster size for each boat.

Today most pleasure craft over 35' have a bow thruster as standard equipment which normally will meet the expectations of most customers when using the boat under normal weather conditions. The sizes used by the boat builders will vary depending on the boat's intended usage and price level. In today's production boats, the typical thruster will push the boat's bow against a direct side wind of 21-23 knots.

Some custom built or very high end boats may have a high power bow thruster that pushes the bow against a direct side wind of 24-26 knots. For boat owners that use their boats in more demanding conditions or have, for example, a strong current in their local marina, or for other reasons require very high performance, many boat builders offer upgrades to a more powerful thruster system. While most pleasure crafts will have ample power in most conditions when the thruster can push the bow against a direct side wind of 25-27 knots, this year's addition of the "DC Speed Control" system will allow for even more powerful DC electric thrusters to be used comfortably.

Charts

The charts shown here are general guidelines and your dealer will be able to give more detailed advice on the thruster size to use for your boat.

Example

If you have a 45' / 13.5m boat, you have 4 thrusters to choose from within "normal" sizing.

If your boat does not have a lot of wind area and you use it mostly in good weather conditions, you can choose the least powerful thruster, the SE80 in a 185mm tunnel.

If you want to keep the ø185mm tunnel dia, but require more power, the SE100 is a good choice.

If you have room for a larger tunnel diameter, there are models in both ø215mm and ø250mm tunnels that are suitable for this boat size, so there are many options.

Please note that generally, a larger tunnel diameter will be more energy efficient and generate less noise.

Conclusion

The two main factors that decide correct thruster sizing are:

- boat owner's performance requirements
- boat size, type and shape

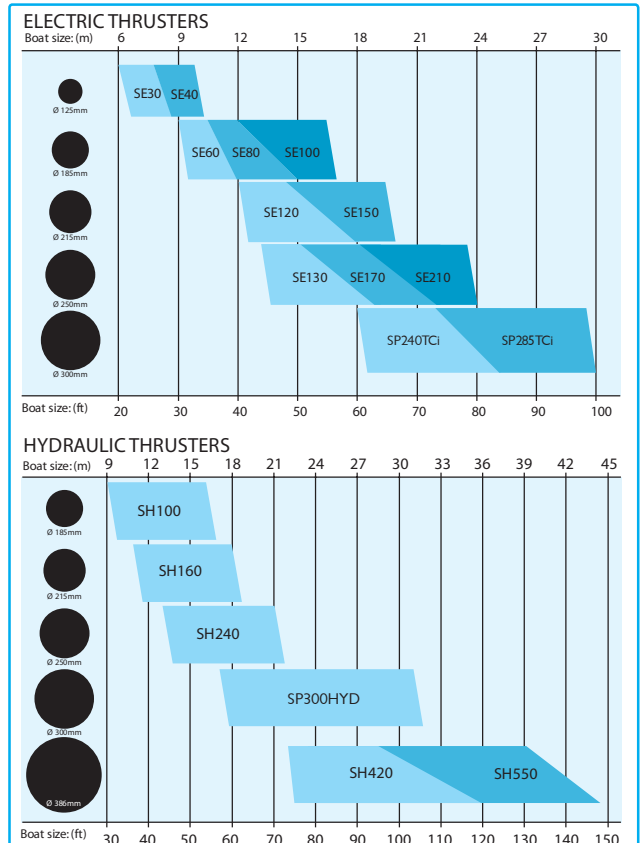
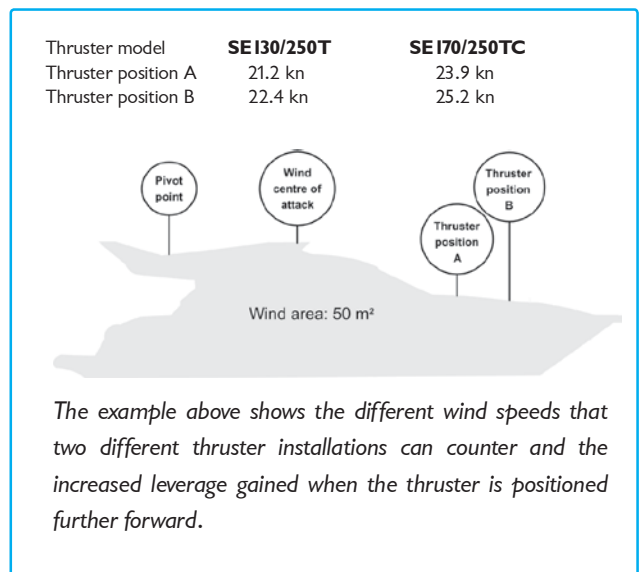

DC thruster models

To enable the most safe and easy installation as well as the best possible performance for a variety of boats and usages, Side-Power thrusters are offered in several versions to satisfy all requirements.



SE series – Standard bow and stern thrusters

The standard bow and stern thruster series are the base for all our extensive range of DC electric thrusters. They are fitted in a tunnel through the bow, or into our stern tunnels to use as a stern thrusters. The electric motors, solenoids, patented IPC control system and the mechanical parts of the propulsion system are all totally custom designed and built, utilizing the extensive experience gained through years of leadership in the global thruster market.

IP versions – For demanding environments

The IP – ignition protected – versions are equipped with a hermetically sealed cover around the motor and switch gear. This means that it is safe to use in gasoline boats or other areas where there is a risk of explosive fumes as well as excellent for installation in wet areas (not for submerged installation). Can be used for both bow or stern applications. Most models in both the SE and SEP series are available in IP versions. More information page 10.



SR series – Retractable thrusters

Our retractable thrusters are excellent for use as bow or stern thrusters in boats with shallow or flat bottomed hulls, or where a tunnel opening in the hull at all is not desirable. Designed in true Side-Power spirit with reliability and durability as main factors, they are exceptionally sturdy and compact with the same high performance as all other Side-Power thrusters. Unique advantages by use of the latest technology including our S-link intelligent bus control provides a further benefit in use and control for the operator. Available also as speed control versions with the designation SRP. More information on page 11.

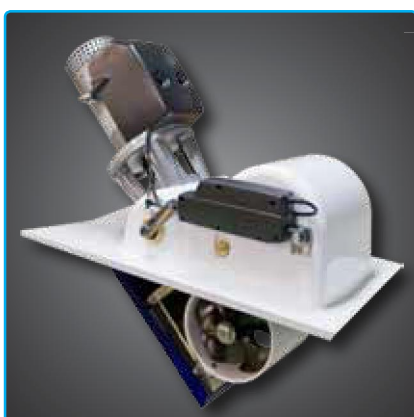

SX versions – Externally fitted stern thrusters.

The fully external stern thrusters. Very popular for boats with twin stern drives together with the special cowls directing the water flow past the drives or in boats that have limited internal space in the back of the boat. Exceptionally easy installation is a bonus with the SX stern thrusters. Two size models are available now, the 80 and 100 kg thrust models and you can get both SE and SEP series in SX versions. More details on page 12.



SEP series – The speed controlled thrusters

The SEP series are basically SE thrusters with the addition of the DC Powercontrol system. Providing even more accurate control by fully regulating the power of the thruster as well as providing even longer run times, this is the latest in DC electric thrusters. The noise reduction and automatic "Hold" function are further benefits provided by the SEP series. More details on page 14.

Planning your system

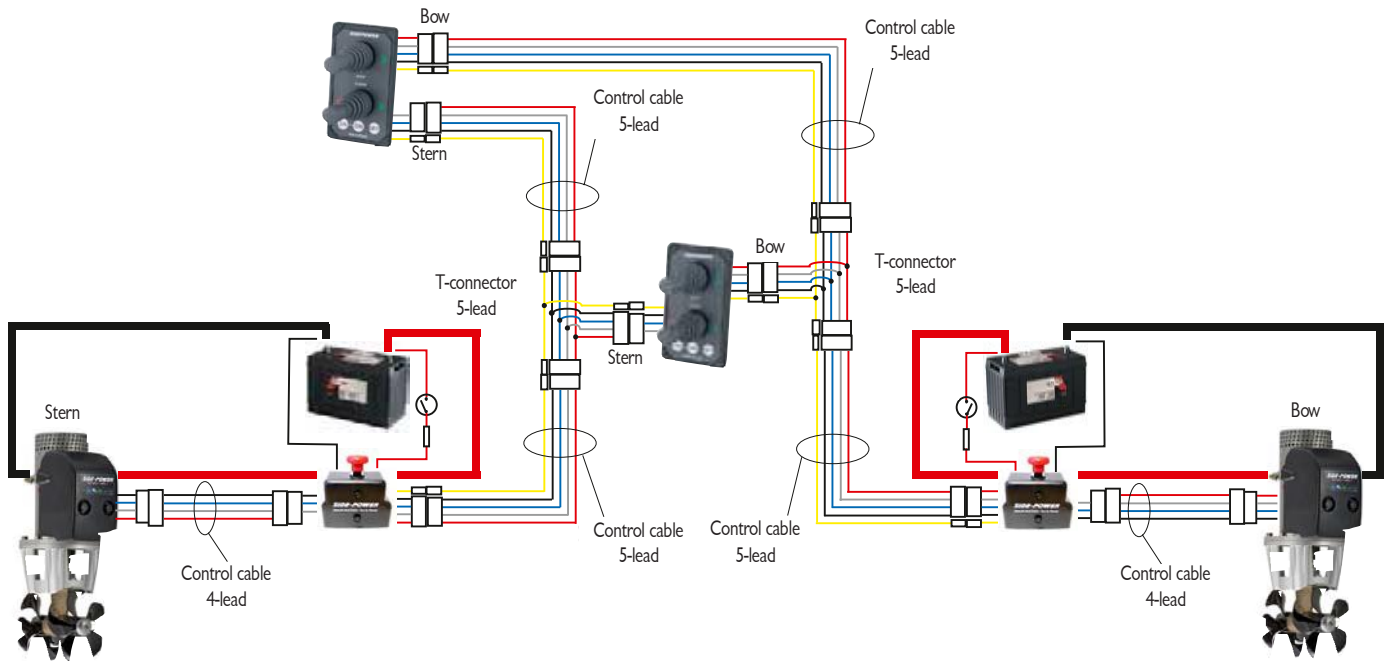

A complete thruster system

There are several components in a complete system for your boat; besides the thrusters and tunnels (bow or stern or both) – you will need control cables, main switches – automatic or manual – fuse & fuse-holder, control panel(s) and main power cables, even a radio remote is a normal part of a thruster system today. To simplify installation and further increase the safety, we recommend to use the original Side-Power Automatic Main switch which also has a built in fuse reducing the number of necessary components. Where the Automatic Main switch is used, you need a 5 lead control cable between the panel and main switch, while only a 4 lead is needed to the thruster or if a manual or other auxiliary main switch and separate fuse is used.

The powerful electric motors used on the thrusters require a good electric power supply for safe operation and to achieve the desired power. Thereby, both the main power cable sizes as well as the available battery capacity is important. It is the actual delivered voltage at the thruster when it is running, after the voltage drop both in the batteries as well as through the cables, main switch and fuse, that decides the actual power of the electric motor and thereby the possible thrust. So, getting this right will be important for your product satisfaction. It is also important to remember that different types of batteries have different capabilities and specialties, and what is important for thrusters is the cranking capacity, the batteries ability to deliver a high current for a shorter period of time. On www.side-power.com you will find a guide called “system builder” – that will guide you through what parts to order as well as recommend cable sizes and battery capacities for your chosen thruster(s).

The Side-Power “System builder” will help plan the installation in your boat.

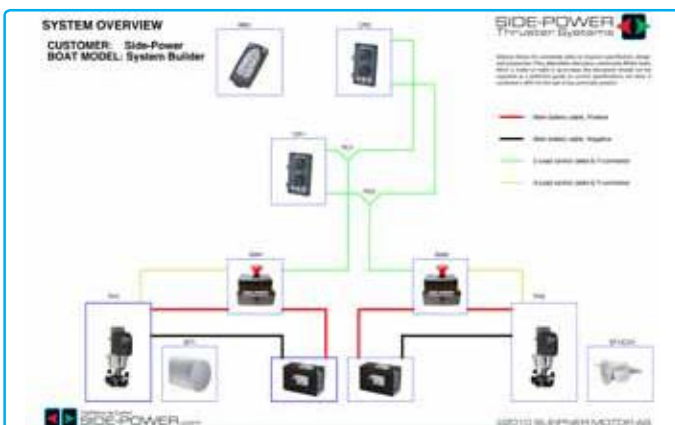

Part No.	Description
2	SE80/100T-12V Sidepower 80kg Thruster, IPC, Twin 50 Q prop, sealed bearing, 12V, 1100mm
1	9001 Tunnel GNP 185 x 850 x 8 mm for SE80, SE80, SE100, SP100
1	90066 Sternthruster tunnel Composite 185x for SE80/SE100/SP100
1	90075 Coax for 1180mm sternthruster tunnel, short model - kit of two GNP
2	907912 A Compact automatic main switch for all Thrusters 12V - with manual shut down NEW
2	AN6-603 AN6 type fuse, 400A for SE90/10 - SP100/20
2	8960 Dual purpose panel New 2000 - 120W (Bow + sternthruster) round hole
1	8980 Side-Power 'Voyager' Radio control kit for two Thrusters, Waterproof, strap, holder etc.
2	8 1275-048 4-lead control cable 4 lead system
4	8 1276-048 4-lead control cable - 5 lead for panel to new main switch/fuse
2	8 1273 T-connector for control to 5 lead below panels and new main switch



Ultimate docking!

With many boat customers now having had several boats with thrusters, their functional demand of their thruster system has increased so that many choose to upgrade to more powerful thrusters than standard and even request hydraulic thruster systems to ensure that run-time limitations in DC electric thrusters will not be a problem. However, very powerful single speed thrusters can, in light weather conditions, be a bit difficult to use as they push the boat too fast, and with the focus on living space in modern boats, often there just is no room for a hydraulic system. The solution is to fit the new Side-Power DC Speed Controller which enables proportional speed control of a DC electric thruster. By also controlling the thruster's power, you get even more precise handling of the boat in all conditions. By also using an upgraded thruster size, you will about never need full power, which means that

the usable run time is extended a lot, at around 50% load you can expect close to continuous usage being possible, normally then limited to battery power.

The extended runtime is put to good use in the Hold-function incorporated in the new panels. With a single press of a button, the bow and stern thrusters will keep you alongside the docks. The amount of thrust applied can be adjusted, and in addition the bow and stern thruster can be individually synchronized to get a balanced sideways motion - making single handed docking very easy indeed!

The DC Speed Control system is controlled by S-link and monitors important parameters such as temperature in both controller and thruster as well as thruster voltage - this monitoring will also enable

greatly simplified troubleshooting for most issues ever seen with thrusters as it shows both actual voltage on the thruster as well as current draw.

The Proportional Joystick Control Panels features a Back-lit LCD display giving instant feedback to the user. System status, amount of thrust & direction of thrust as well as remaining run time and battery capacity will be shown in real time on the display. Important user warnings and alarms will be given to the user both on screen and via audible signals.

Even more functionality by adding a Side-Power radio remote!

When a Side-Power radio remote is added to the system you get even more benefits from the speed control system. If you are docking alone - having the PJC panel automatically pushing the boat against the dock while you go put the mooring lines on, you might wish to increase the thrust on the bow thruster momentarily to make it really tight. Pressing the bow thruster button on the remote will then let you do this. You can also shut down the hold function without going to a fixed control panel by selecting to run any of the thrusters in opposite direction of what the hold function is doing.





System features

A DC Speed Control system contains three main elements - proportional control panels, a power control unit and a DC electric thruster - all tied together with the new S-link control system. The thrusters used in a speed control system is almost identical to the familiar SE range of DC thrusters, the only difference being the addition of a temperature sensor and a new electronic control box. All mechanical and main electric parts are from the well proven thruster range produced by Side-Power for many years. All 12 & 24 volt DC electric thrusters produced by Side-Power can be enabled for DC Speed Control by authorized Side-Power service personnel, even the oldest models.

PJC 212 Control Panel

- Plug and play S-link control cable wiring (waterproof plugs)
- Finger tip control with purpose designed joysticks
- Hold - function for easy docking, runs thrusters at selected power
- Back-lit LCD display with instant feedback
 - Amount of thrust & direction of thrust
 - Thruster temperature/remaining run time
 - Battery status
 - Selectable LCD colour & level for both night and day
 - System monitoring simplifies troubleshooting
- Interactive multilingual menus
- Built-in audible alarm "buzzer"

PPC 800 Power Control Unit

- Plug and play S-link control cable wiring
- Easy to access, solid main cable terminals
- Easy to place as it can be located anywhere between the batteries and the thruster, also in areas requiring ignition protected parts
- Reliable solid state switching
- Thermal and over current protection
- Active cooling for continuous usage

Thruster for DC Speed Control

- Any Side-Power DC Electric thruster can be upgraded to DC Power Control specification
- Temperature monitoring through PPC800
- Increased directional solenoid lifetime because the solenoids will not switch with load
- IPC intelligence for extra safety



"Easy does it with variable-speed thrusters"

"...Until now the luxury of adjusting how much thrust you use to manoeuvre a big boat in or out of a tight spot has been the preserve of expensive and bulky hydraulic thruster systems. Sleipner's new 12/24V system is a much more cost effective set-up and considerably more compact than a hydraulic system. It should also help resolve the issue of not being able to use an electronic thruster for long periods of time without overheating, because you'll rarely be using it on full power all the time..."

"...Using conventional DC thrusters, offering full power or nothing, we would have had to apply numerous bursts to keep it rotating. With the variable-speed system we were able to use a smaller amount of continuous thrust. Not only was this more intuitive, but it made for a quieter, more relaxed manoeuvre. The more power you want, the more you push the twin paddle switches..."

"...This means that like a hydraulic system it also has a hold function, enabling you to set and leave the level of thrust. It's a feature that short-handed skippers often rely on to pin their boats against the dock while they step off to secure the lines..."

"...The other big bonus is a remote control that allows you to operate both thrusters from wherever you chose, so you can take up station on the side deck and walk the boat in while keeping an eye on the gap..."



MOTORBOAT & YACHTING - NOVEMBER 2010





S-link



S-link System

S-link is a "CAN" based control system with full intelligent communication between all units in the system, much like a computer network.

Main advantages include:

- Round, compact and waterproof plugs with unique keying and color coding to avoid faulty hookup
- Unlimited number of commands or information transfer on a single cable
- User feedback at panel
- Intelligent troubleshooting

S-link cable component overview

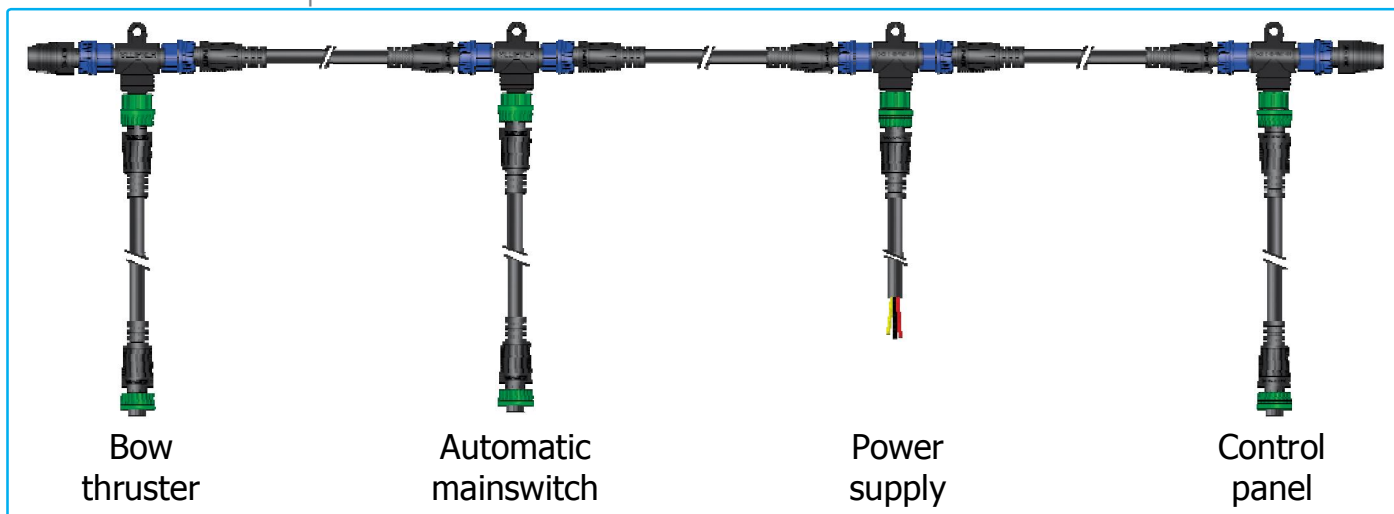

BACKBONE cables

Forms the main "loop" around the boat.

Part #: 6 1320-xxM (xx=length)

- 6 1320-0,2M (0,2m)
- 6 1320-2M (2,0m)
- 6 1320-4M (4,0m)
- 6 1320-7M (7,0m)
- 6 1320-15M (15,0m)
- 6 1320-20M (20,0m)



SPUR cables

Must be used to connect all parts to the backbone cable (one for each component, no exceptions), recommended to be as short as practically possible.

Part #: 6 1321-xxM (xx=length)

- 6 1321-0,4M (0,4m)
- 6 1321-1M (1,0m)
- 6 1321-3M (3,0m)
- 6 1321-5M (5,0m)

POWER cable

Must be one in each system, length 2.5m

Part #: 6 1328



BACKBONE EXTENDER

Connects two backbone cables to extend length.

Part #: 6 1322



T-CONNECTOR

Must be one for each spur, including power cable.

Part #: 6 1326

END TERMINATOR

Must be one in each end of the backbone "loop".

Part #: 6 1327



CanBus control system

Examples of the control wiring with S-link system for boats with two control positions and two DC proportional thrusters. Depending on the boat's construction, there might be several different ways to route the S-link backbone. Find the most practical way to implement the backbone and remember that the S-link equipment do not need to be connected in a specific order.

- 2 x 6 1327 End terminators
- 7 x 6 1326 T-connectors
- 1 x 6 1328 Power spur
- 6 x 6 1320-xxM Backbone cables
- 6 x 6 1321-xxM Spur cables

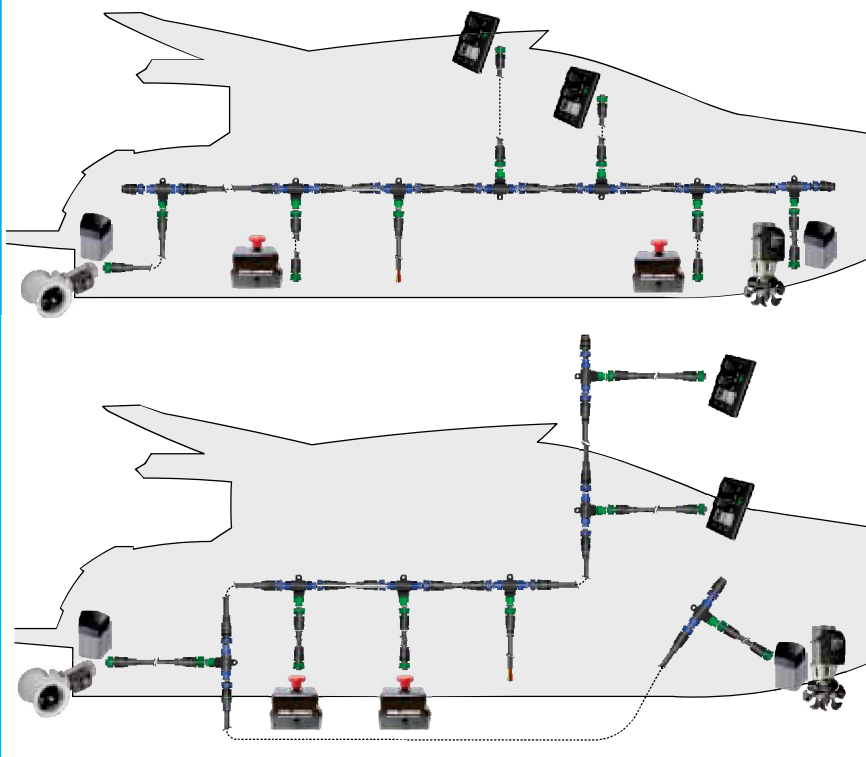

Example of the control wiring with S-link system for boats with one control position and one retractable thruster

- 2 x 6 1327 End terminators
- 4 x 6 1326 T-connectors
- 1 x 6 1328 Power spur
- 3 x 6 1320-xxM Backbone cables
- 3 x 6 1321-xxM Spur cables

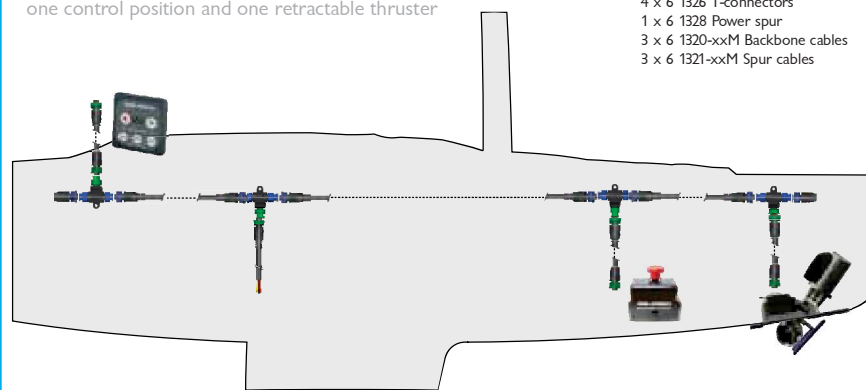

Example of the control wiring with S-link system for boats with one control position and two DC proportional retractable thrusters

- 2 x 6 1327 End terminators
- 6 x 6 1326 T-connectors
- 1 x 6 1328 Power spur
- 2 x 6 1320-xxM Backbone cables
- 5 x 6 1321-xxM Spur cables

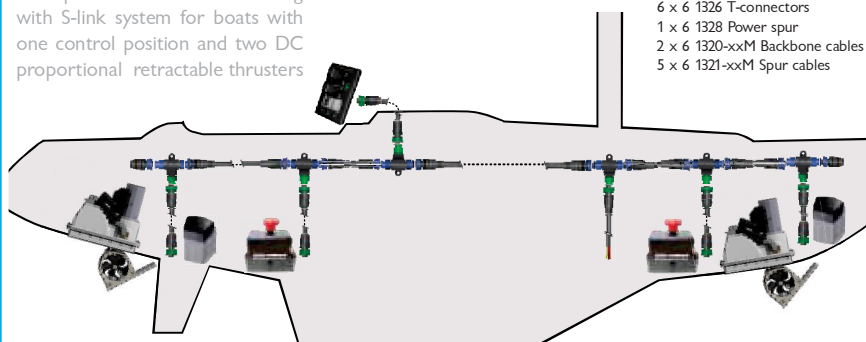

Side-Power features



The new 5 blade special skew propellers are the result of over 2 years of development work and thousands of tests. They have been designed to reduce the noise level, while maintaining the exceptional efficiency of the old 4 blade Side-Power propellers. This goal was achieved, and we even chose to make a little bit more aggressive on some models, increasing the thrust on most thrusters. Please see individual information on each new thruster for more details.

- Noise reductions of up to 75% measured in controlled environments
- The expected and tested normal noise reduction in “average installations” 20-40%
- Standard on all Side-Power models except the SH420/386TC and SH550/386TC
- Upgrade kits are available for most “SP” series thrusters with special adaptors



The gearhouse / drive legs of most Side-Power DC Electric thrusters are now fully galvanically isolated / separated from the electric motor and motor bracket. This ensures that even if there is an accidental short circuit or a current leak for other reasons, the immersed parts are not effected as they could be with direct electric contact.

- Achieved by composite bushings around the bolts and beneath the washers and a bushing in the motor bracket electrically isolating the drive housing from the motor bracket.
- Available on DC electric models with flexible couplers only, where the flexible coupler provides galvanic separation of the motor and gearleg shaft.



The Side-Power unique thruster controller that intelligently protects the thruster from potential inherent problems in all high current applications as well as user faults. It includes several important safety features imperative in a product with such high power, run by DC electrics, as a thruster.

- Provides delay between drive directions
- Monitors solenoid functions to reduce the chance of solenoid lock-in
- Will stop the thruster in case of a locked-in solenoid, without extra user action and even without controlling a main switch.



To provide reliable and safe thruster installations in more boats, we offer modified versions of our DC electric thrusters in watertight housings for use in stern and other locations that may get wet or be exposed to petrol fumes. These thrusters are fully ignition protected (ISO 8846) for use in boats with petrol engines. They have a hermetically sealed composite housing around all electric parts. This provides the ignition protection as no petrol fumes can enter and be ignited by sparks.

The other advantage is that the electric parts that could be damaged by water are also covered and protected, making these thrusters the ideal choice for other stern thruster installations where it is difficult to ensure that the thruster will always remain dry.



The difference is in the details



The thruster gearleg is filled with oil from a remote reservoir located above the waterline. This generates overpressure, making an effective seal against water intrusion in the gear leg.

- Separate oil reservoir placed above the waterline.
- Allows easy access for oil changes
- Having the advantage to be able to change oil in units used commercially, with hundreds of running hours per year.



Sealed gear leg with long-life “mechanical” seal where highly polished ceramic and carbon surfaces form the only moving sealing surfaces, ensuring protection against damaging water intrusion into the gear leg. Pre-filled with special gear oil for lifetime lubrication.

- “Mechanical” seals with surfaces of ceramic and carbon for ultimate security against water intrusion



SINGLE PROPELLER:

A properly engineered single propeller system will be the most energy efficient thruster. Its compact design fits easily into narrow bows making it the perfect match for our smaller models. With more than 70000 single propeller thrusters in use, the Side-Power single series system has proven its reliability.



TWIN PROPELLERS:

The twin propeller system can give more thrust than a single propeller system in the same tunnel diameter. This is our choice for our mid-range models where high thrust is required in a small tunnel diameter. Due to the compact design and high performance, the twin models have become the thrusters of choice among boat builders around the world.



TWIN COUNTER ROTATING PROPELLERS:

Two counter-rotating propellers can give the most thrust at a good performance ratio in a minimal tunnel diameter. This system is used in our larger thrusters for maximum power. The TC models are the favourite thrusters among leading boat builders for their high-end yachts.



∅ 125 mm



∅ 185 mm



∅ 215 mm



∅ 250 mm



∅ 300 mm



∅ 386 mm



With the ever growing demand for increased performance, we continue to expand our offering of tunnel diameters to allow customers to choose more powerful thrusters in tunnel sizes that will fit in their boat. The latest addition is the 215mm tunnel, between the existing ∅185mm and ∅250mm sizes. This size is very important for boat sizes around the 50' / 15m mark, where we have seen that boats have become much more voluminous than before, requiring larger thrusters to achieve the same maneuverability. We will continue to launch new tunnel diameters where appropriate to let our customers get the performance they want in their boats.

Facts about tunnel sizes:

- Principally a larger tunnel diameter will always be more energy efficient than a smaller tunnel diameter for the same thrust. The factor is water speed, and this is decided by the amount of water you move through the possible opening which is the square area of the tunnel less the area blocked by the thrusters gearleg.
- The opening in the boat hull is not only the circular size of the tunnel diameter. Because the hull is angled, you get a much larger oval opening, and this makes a larger tunnel diameter more difficult to fit properly into the hull.

∅ 513 mm

∅ 610 mm

New tunnel sizes for the SH1000/1400



DC thruster range



SE Series thrusters	SE 30/I25 S	SE 40/I25 S	SE 60/I85 S	SE 80/I85 T	SE 100/I85 T	SE 120/215 T
Thrust at 10.5V/21V* (kg • lbs)	30 • 66	40 • 88	60 • 132	80 • 176	100 • 220	120 • 264
Thrust at 12V/24V* (kg • lbs)	40 • 88	48 • 105	73 • 161	96 • 212	116 • 256	139 • 306
Typical boat size (ft • m)	20' - 28' • 6 - 8.5	26' - 34' • 8 - 10.5	29' - 38' • 9 - 12	35' - 48' • 10 - 15	35' - 55' • 12 - 17	42' - 60' • 13 - 18
Tunnel I.D. (mm • in)	125 • 4.92"	125 • 4.92"	185 • 7.3"	185 • 7.3"	185 • 7.3"	215 • 8.46"
Propulsion system	Single	Single	Single	Twin	Twin	Twin
Power at 10.5V/21V* (kw • Hp)	1.5 • 2	2.2 • 3	3.1 • 4	4.4 • 6	6.3 • 8.4	6.4 • 8.55
For DC system (V)	12	12	12/24	12/24	12/24	24
Weight (kg • lbs)	9.5 • 21	10 • 22	16 • 35	20 • 44	31 • 68	34 • 74
Min. Batt. Cap (CCA**12/24V)	200	300	350 • 175	550/300	750/400	400

Item Code 12V	SE30/I25S(-IP)	SE40/I25S(-IP)	SE60/I85S-12V(-12IP)	SE80/I85T-12V(-12IP)	SE100/I85T-12V(-12IP)	SE120/215T (-IP)
Item Code 24V			SE60/I85S-24V(-24IP)	SE80/I85T-24V(-24IP)	SE100/I85T-24V(-24IP)	



AVAILABLE AS SPEED CONTROL THRUSTERS



SX Series thrusters	SX 80/I85 T	SX 100/I85 T	SR Series thrusters	SR 80/I85 T	SR 100/I85 T
Thrust at 10.5V/21V* (kg • lbs)	80 • 176	100 • 220	Thrust at 10.5V/21V* (kg • lbs)	80 • 176	100 • 220
Thrust at 12V/24V* (kg • lbs)	96 • 212	116 • 256	Thrust at 12V/24V* (kg • lbs)	96 • 212	116 • 256
Typical boat size (ft • m)	35' - 48' • 10 - 15	35' - 55' • 12 - 17	Typical boat size (ft • m)	35' - 48' • 10 - 15	35' - 55' • 12 - 17
Tunnel I.D. (mm • in)	185 • 7.3"	185 • 7.3"	Tunnel I.D. (mm • in)	185 • 7.3"	185 • 7.3"
Propulsion system	Twin	Twin	Propulsion system	Twin	Twin
Power at 10.5V/21V* (kw • Hp)	4.4 • 6	6.3 • 8.4	Power at 10.5V/21V* (kw • Hp)	4.4 • 6	6.3 • 8.4
For DC system (V)	12/24	12/24	For DC system (V)	12/24	12/24
Weight (kg • lbs)	52 • 115	57 • 125	Weight (kg • lbs)	31 • 68	44 • 97
Min. Batt. Cap (CCA**12/24V)	550/300	750/400	Min. Batt. Cap (CCA**12/24V)	550/300	750/400

Item Code 12V	SX80/I85T-12V	SX100/I85T-12V	Item Code 12V	SR80/I85T-12V	SR100/I85T-12V
Item Code 24V	SX80/I85T-24V	SX100/I85T-24V	Item Code 24V	SR80/I85T-24V	SR100/I85T-24V



AVAILABLE AS SPEED CONTROL THRUSTERS



SE I30/250 T

SE I50/215 T

SE I70/250 TC

SE 210/250 TC

SP 240 TCi

SP 285 TCi

130 • 284	150 • 330	170 • 374	210 • 462	240 • 528	285 • 627
160 • 352	182 • 400	210 • 462	250 • 550	300 • 660	340 • 748
42' - 62' • 13 - 19	44' - 64' • 14 - 20	50' - 70' • 15 - 22	55' - 78' • 17 - 24	60' - 84' • 18 - 25	74' - 100' • 22 - 30
250 • 9.8"	215 • 8.46"	250 • 9.8"	250 • 9.8"	300 • 11.8"	300 • 11.8"
Twin	Twin	Twin Counter rot.	Twin Counter rot.	Twin Counter rot.	Twin Counter rot.
6.5 • 8.7	8.8 • 11.8	8 • 10.7	10 • 13.15	11.4 • 15.5	15 • 20
12/24	24	24	24	24	24 (48V motor)
37 • 77	38 • 79	44 • 97	68 • 150	70 • 154	73 • 160
750/400	560	550	650	700	2x450 - 24V

SEI30/250T-12V(-I2IP)
SEI30/250T-24V(-24IP)

SEI50/215T

SEI70/250TC(-IP)

SE210/250TC

SP240TCi

SP285TCi



SR I30/250 T

SR I70/250 TC

SR 210/250 TC

130 • 284	170 • 374	210 • 462
160 • 352	210 • 462	250 • 550
42' - 62' • 13 - 19	50' - 70' • 15 - 22	55' - 78' • 17 - 24
250 • 9.8"	250 • 9.8"	250 • 9.8"
Twin	Twin Counter rot.	Twin Counter rot.
6.5 • 8.7	8 • 10.7	11 • 14.5
12/24	24	24
82 • 181	88 • 194	112 • 247
500/250	550	650

SR I30/250T-12V
SR I30/250T-24V

SR I70/250TC-24V

SR 210/250TC-24V



The following models can be delivered as Speed Control Thrusters with the PPC800 control unit included:

SEP80/185T	SEP80/185T-IP	SRP80/185T
SEP100/185T	SEP100/185T-IP	SRP100/185T
SEP120/250T	SEP120/250T-IP	SRP130/250T
SEP130/250T	SEP130/250T-IP	SRP170/250TC
SEP150/215T	SEP170/250TC-IP	SRP210/250TC
SEP170/250TC	SXP80/185T	
SEP210/250TC	SXP100/185T	
SEP240/300TC		
SEP285/300TC		



The current range of on/off thrusters can be upgraded to Speed Control specifications - see page 25 for details. Older models can also be upgraded for use with a Speed Control system, check our website or contact your local distributor for more information on available upgrade kits.

* All Side-Power thrusters gets their thrust rating from the actual performance you can expect in a boat, at the voltage a normal installation will provide at the thruster. We have chosen to use the net performance at 10.5V/21V, but we also list the effect at 12V/24V for comparison.

** All Battery CCA Ratings are stated at the DIN Rating, multiply by 1.9 to equal the SAE rating at 0°F which is ABYC standard



The difference is in the details

Side-Power Benefits



1 Compact sized and modern styled control panels with hidden screw heads.



2 The round cut-out hole, the pre-fitted seal and easy front mount with hidden screws ensures fast and flawless installation.



3 Side-Power thrusters come standard with an integrated processor, protecting the unit against operator errors and technical problems

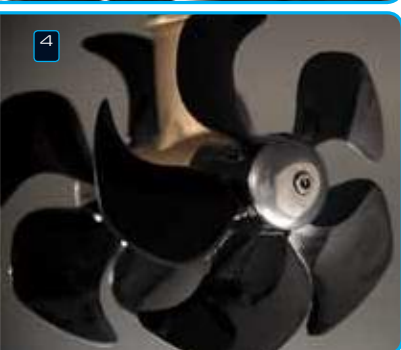

4 Lightweight, sturdy and non-corrosive, composite propellers are perfect for thrusters of all sizes.

5 Hardened spiral-cut gears for extended lifetime, low noise and more compact gearleg design.

6 Machined and assembled to perfect tolerances, using high end purpose made components ensures extended lifetime for professional use.

7 Side-Power developed electric motors for maximum performance and efficiency in real-life onboard conditions. Details increasing safety and ease of installation are standard.

8 The child safe on/off system minimizes the risk of accidental or unintentional operation.

9 While other joysticks might appear similar, the unique Side-Power joysticks are made of fully UV protected silicon based rubber to ensure long term reliability.

10 Side-Power's zinc anodes are outside the propellers for easy access and replacement

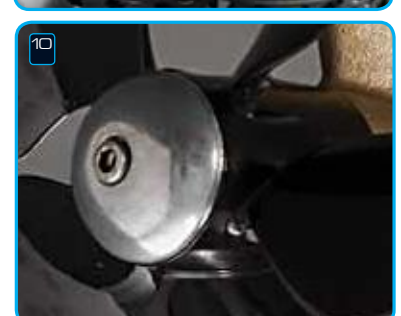
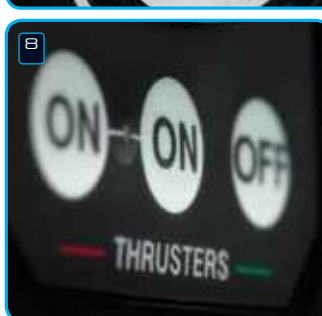

External sternthruster - the SX series



Finally a functional stern thruster option for boats with twin stern drives!

Side-Power now offers a complete external sternthruster assembly, specially designed for installation on boats with twin stern drives. It utilizes special cowls to enable good performance by diverting the waterflow past the stern drive legs, which normally blocks the v and the thrust.

The units come pre-assembled, wired and sealed in the waterproof box, and only require a small hole into the boat's transom to attach the power and control cables. The cable connection points are fully sealed, so that it is Ignition Protected and can be installed in petrol powered boats.

This stern thruster option can also be the best choice for boats without stern drives, if the inside configuration of the boat's stern makes a standard thruster installation impractical.

Available with two different size thrusters, SX80 and SX100. Also available in SXP versions with DC speed control.



Ignition protected - the IP series



For several years, Side-Power has manufactured ignition protected thruster models. Now, the second generation is here with added features and many more models.

High safety standards

To provide reliable and safe thruster installations in more boats, we offer modified versions of our DC electric thrusters in watertight housings for use in stern and other locations that may get wet or be exposed to petrol fumes. These thrusters are fully ignition protected (ISO 8846) for use in boats with petrol engines. They have a hermetically sealed composite housing around all electric parts. This provides the ignition protection as no petrol fumes can enter and be ignited by sparks. The other advantage is that the electric parts that could be damaged by water are also covered and protected, making these thrusters the ideal choice for other stern thruster installations where it is difficult to ensure that the thruster will always remain dry.

Ignition Protected Features

- Certified to ISO 8846 Ignition Protected standards
- Water Proof (not for submerged mounting)
- Stainless cable seals
- Manufactured, tested and delivered as a ready sealed unit, ensuring that the installer does not have to fit any other parts that can jeopardize the hermetical seal
- Supplied with 1 m/3.28 ft main power cables and termination blocks for easy and safe installation
- Supplied with 1 m/3.28 ft plug and go control cable
- Ignition protected housing can be opened and thereby retains serviceability of components inside the enclosure
- Available as SEP-IP versions with DC Speed Control.

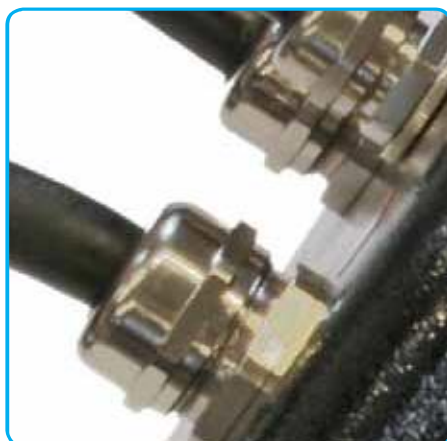

Tunnels and stern thruster kits

Tunnels

GRP tunnels are available in several lengths for each thruster model. They are purpose built for our thrusters and provide ultimate strength, accuracy and osmosis protection to ensure an easy and safe thruster installation. The wall thickness is adapted to each thruster's power and boat size. We also offer a selection of aluminium and steel tunnels.



Stern thruster kits

These transom-mounted tunnels are meticulously designed to enhance the performance of the thruster. Manufactured in fibreglass, they are extremely strong and durable. The complete installation is very easy and meets the high Side-Power standards. The additional cowls make it possible to allow a stern thruster installation in boats with shallow draft or obstructions on the stern.

Injection mould stern tunnels

Injection mould tunnels with extra safety features; 30% stronger and specific breaking point design. Available for 125mm, 185mm and 250mm tunnel diameter thrusters. The new 250mm tunnel features split tunnel assembly for easier installation and integrated support for thruster motor and bracket, eliminating the need for an external support strut.

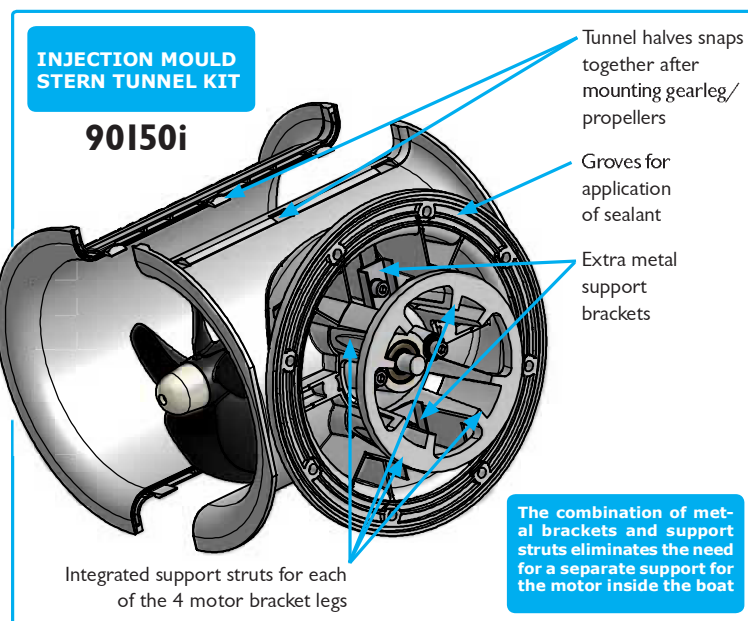

Stern tunnels & cowls:

Item code	SE 30/40	SE 60	SE 80/100	SE 120/150
Stern thruster kit	90124i	90052i	90086i	90135i
Cowls - short model	-	90075	90075	-
Cowls - long model	90126	90077	90077	90136

Item code	SE 130/170	SE130/170	SE210	SP 240 / 285
Stern thruster kit	90140i	90150i	90180i	90200i
Cowls - short model	-	-	-	-
Cowls - long model	90132	90132	90132	90220

Item code	SH 100	SH 160	SH 240	SP300HYD	SH 420/550
Stern thruster kit	90086i	90135i	90140i/90150i	90200i	90550
Cowls - short model	90075	-	-	-	-
Cowls - long model	90077	90136	90132	90220	90560



Control cables

Make sure that the complete installation meets the Side-Power quality standard and take advantage of our "Plug & Go" wiring system by using original control looms. They are available in many different lengths and Y-connectors tie multiple control positions together. Colour coded to match the wiring diagrams with high quality connectors to ensure a correct installation.





Retractables - the SR series



185mm tunnel diameter

Some boats do not have the possibility to fit a tunnel thruster and thereby require a retractable thruster. Side-Power have talked to the market and identified the weaknesses in existing solutions and improved these to offer retractable thrusters in true Side-Power spirit with no compromise on safety and reliability.

The retracting thrusters are built with the same high safety standards as all Side-Power products, and incorporate all features introduced with the SE-series thrusters. Our focus on safety is a totally integral part of the product design so that everything from build quality to ease of installation is thought of to ensure long term reliability.

The 185mm retractable thrusters are available in the following models:

SR80/185T - 80kg thrust, available for 12V and 24V

SR100/185T - 100kg thrust, available for 12V and 24V



Specific Retracting thruster features

- Plug and play S-Link two way communication control cable wiring
- Motor assembly rigid mounted on retract casing - no moving parts during retract operation
- Compact measures
- Reliable retract mechanism, avoids sticking
- Fast deployment time
- Easy to use control panel with status feedback from thruster
- Available as SRP versions with DC Speed Control.



250mm tunnel diameter

The new retractable thrusters for 250mm tunnel diameter features a split casing for easier installation and maintenance as well as dual actuators to handle the heavier load.

The design has also been revised to get the thruster as compact as possible even with the heavier motors required for the higher performance of these models.

The 250mm retractable thrusters are available in the following models:

SR130/250T - 130kg thrust, available for 12V and 24V

SR170/250TC - 170kg thrust, 24V

SR210/250TC - 210kg thrust, 24V

Specific Retracting thruster features

- Plug and play S-Link two way communication control cable wiring
- Motor assembly rigid mounted on retract casing - no moving parts during retract operation
- Compact measures
- Split casing for easy installation and maintenance
- Reliable retract mechanism, avoids sticking
- Fast deployment time
- Easy to use control panel with status feedback from thruster
- Available as SRP versions with DC Speed Control.



Control panels for DC thrusters

Side-Power offers a unique series of «smart» control panels, an important part of a thruster system. Choose between our compact touch button, the popular joystick controls, the «docking» control panel with the most intuitive thruster control ever or the new exclusive round panel. Why not try the radio remote control for full mobility onboard, being the perfect tool for shorthanded boating. Radio linked panels are also an option. Mix or match, the choice is yours!

Easy installation

- round cut-out hole (std.instrument size)
- installs from front side
- pre-fitted O-ring seal
- multi-voltage (12 & 24V)

Safety

- child-safe on / off system
- power / control light
- automatic deactivation
- easy operation

Quality

- waterproof (IP65-front)
- UV safe
- CE -approved

Design

- compact size
- modern styling
- no visible screw heads



Control Panel	Item code	H (mm)	W (mm)	No. thrusters
Touch panel	8950 G	70	70	1
Round touch panel	8955 G	ø 86,5	-	1
Joystick panel	8960 G	70	70	1
Boat switch panel	8965	ø 86,5	-	1
Dual joystick panel	8940 G	120	70	2
Docking panel	8909 C	120	70	2

Handheld radio remotes

A radio remote control makes your thruster system even more helpful around the docks. Providing full simultaneous control of a bow and a stern thruster or a bow thruster and a windlass, making shorthanded boating much easier.

	Radio remotes
H (mm • in)	95 • 3.74 (transmitter)
W (mm • in)	48 • 1.89 (transmitter)

Item code:

Radio remote set (bow + stern thruster) / Radio remote set (bow thruster + windlass) **8980 / 8985**
 Extra transmitter (bow + stern thruster) / Extra transmitter (bow thruster + windlass) **8981 / 8986**





PJC 212 Dual Joystick for DC Speed Control

- Finger tip control with purpose designed joysticks
- Hold - function for easy docking, runs thrusters at selected power
- Back-lit LCD display with instant feedback
 - System status
 - Amount of thrust & direction of thrust
 - Thruster temperature/remaining run time
 - Battery status
- Interactive multi-language menus
- System setup via "wizard"
- Diagnostics via panel/computer interface
- Built-in audible alarm "buzzer"
- Connector for external "buzzer"/loud audible alarms
- Also available for hydraulic systems
- Can be used as ON/OFF panel with SR retractable thrusters

	Dual Joystick
H (mm • in)	141 • 5.55
W (mm • in)	83 • 3.27
Item code (12 & 24V)	PJC212



PJC 211 Single Joystick for DC Speed Control

- Same as PJC212, but for one thruster without hold function.

	Singel Joystick
H (mm • in)	141 • 5.55
W (mm • in)	83 • 3.27
Item code (12 & 24V)	PJC211



8900 S-link Touch Panel for retract thrusters

The compact and flush design keeps smaller dashboards tidy and prevents ropes from snagging on sailboats. LED status indicators reports the status of the SR thruster via S-link, as well as clear and direct service notices.

	Touch panel
H (mm • in)	70 • 2.76
W (mm • in)	70 • 2.76
Item code (12 & 24V)	8700



Accessories

Radio link for control panels

The radio link eliminates the need for difficult cable runs between control panel(s) and thruster. Consisting of a transmitter box, that connects to a control panel and a remote control receiver that plugs into the thruster(s), the receiver accepts up to 4 independent transmitters or hand held radio remotes. The multi-channel system supports two thrusters and can be mixed with hard wired control panels. Full Side-Power safety level with child-safe activation and intelligent auto-off, even at the receiver.

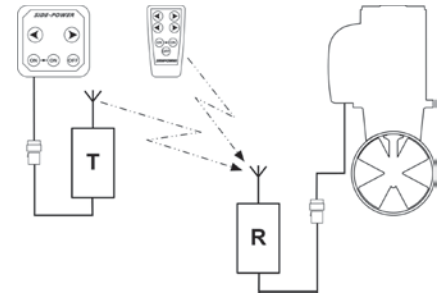

	Item codes:
Radio link kit	8970
Extra transmitter unit for radio link kit	8975

Serial-parallel switch box

This switch box enables the installation of 24V thrusters in boats with a 12V system. With an additional 12V battery, you supply 24V for the thruster's operation, while all batteries are charged by your normal 12V system when the thruster is not running. The reliability of this fully automatic system has been proven in hundreds of boats over many years.

To install 24V thrusters in 12V boats (necessary extra battery is not included)

	For SE 120/130/150/170	For SE200/SP240
H x W x D (mm)	285 x 265 x 110	285 x 265 x 110
H x W x D (in)	11.2 x 10.4 x 4.3	11.2 x 10.4 x 4.3
Item code	I0I12A	I5I12A



Automatic main switch

The most user friendly and safe installation is provided with the automatic main switch/fuse. The main power to the thruster is conveniently controlled by the Side-Power control panel. Added safety is provided by the panel's auto-off and the thruster's overheat sensor, also controlling the main switch. Flexible mounting options, "Plug & Go" wiring, heavy terminals allowing double cables and only one item to fit ensures fast and easy installation.

For Side-Power thrusters (necessary fuse not included)

	12 Volt	24 Volt
H x W x D (mm)	175 x 205 x 140	175 x 205 x 140
H x W x D (in)	6.9 x 8.1 x 5.5	6.9 x 8.1 x 5.5
Item code	897612	897624



Fuse holder / Fuses

Side-Power manufactures fuse holders that are engineered to minimize voltage drop and heating while saving space. Made for ANL type fuses in high current applications, they accept double cables with heavy terminals. The fuse holder is also available with a protective cover. We supply ANL fuses in sizes to match all of our thrusters.

Item code	Fuse	For thruster
ANL150	150A	SE30/125S - SE60/185S-24V
ANL250	250A	SE40/125S - SE60/185S-12 - SE80/185T-24
ANL325	325A	SE100/185T-24 - SE120/215T-24 - SE130/250T-24 - SP285TCi
ANL400	400A	SE80/185T-12 - SE150/215T-24 - SE170/250TC
ANL500	500A	SE100/185T-12 - SE130/250T-12 - SE210/250TC - SP240TCi
ANLHOLD		Fuseholder for all ANL type fuses
ANLHOLD-C		Fuseholder including clear cover





PPC 800 Power Control Unit

- Plug and play S-link control cable wiring
- Easy to access, solid main cable terminals
- Easy to place as it can be located anywhere between the batteries and the thruster, also in areas requiring ignition protected parts
- Reliable solid state switching
- Thermal and overcurrent protection
- Active cooling for continuous usage

To upgrade a standard on/off thruster to a speed controlled thruster, you need a PPC 800 and the internal wiring loom needs to be upgraded with one of the following kits:

8 1997 - Upgrade kit SR80/100

8 1998 - Upgrade kit SE 100/120/210/240

8 1999 - Upgrade kit SE30/40/60/80/130/150/170

Contact your local Side-Power distributor to get the correct upgrade kit for older Side-Power thrusters.

Due to their sealed construction, IP-models (including SX) must be upgraded by an authorized Side-Power Distributor!



8730 S-link Interface

S-link interface to connect footswitches and standard radio remotes/control panels to a S-link system (Footswitches/Panels/Radio Remote not included).

Add a Radio Remote to your S-link system for even easier short handed boating, or footswitches for hands-free operation of your S-link thrusters.

	Interface Box
H (mm • in)	45 • 1.77
W (mm • in)	80 • 3.15
D (mm • in)	145 • 5.70
Item code (12 & 24V)	8730



Foot switch

Foot switch kit suitable for 8730 S-link interface.

Kit contains 2 switches with covers to protect from unwanted operation.

(Cables from switches to 8730 S-link interface not included)

	Foot Switch
W (mm • in)	Ø105 • 4.13
Item code (Kit)	8751



Automatic Main Switch for S-link

The most user friendly and safe installation is provided with the automatic main switch/fuse. The main power to the thruster is conveniently controlled by the Side-Power control panel. Added safety is provided by the panel's auto-off and the thruster's overheat sensor, also controlling the main switch. Flexible mounting options, S-link control cable, heavy terminals allowing double cables and only one item to fit ensures fast and easy installation.

For SidepowerS-link thrusters (necessary fuse not included)

	12 Volt	24 Volt
H x W x D (mm)	175 x 205 x 140	175 x 205 x 140
H x W x D (in)	6.9 x 8.1 x 5.5	6.9 x 8.1 x 5.5
Item code	897712	897724



Measurements

DC Thrusters

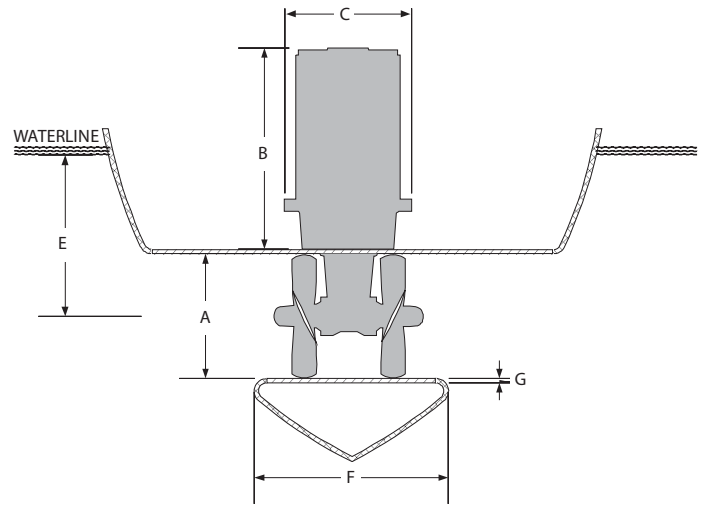
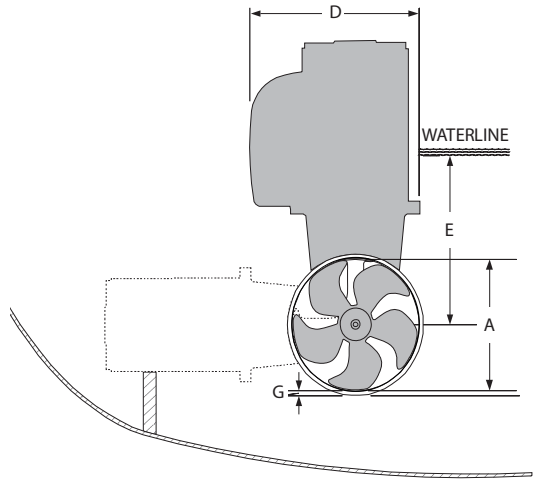

Thruster (mm • in)	A	B	C	D	E _{min}	F	F _{recommended}	G _{min}	G _{max}
SE30/125S	125 • 4.92	234 • 9.2	190 • 7.5	180 • 7.1	125 • 4.9	92 • 3.6	184 • 7.25	4 • 0.16	5 • 0.20
SE40/125S	125 • 4.92	234 • 9.2	190 • 7.5	180 • 7.1	125 • 4.9	92 • 3.6	184 • 7.25	4 • 0.16	5 • 0.20
SE60/185S	185 • 7.3	265 • 10.4	208 • 8.2	197 • 7.8	150 • 5.9	117 • 4.6	234 • 9.2	4 • 0.16	6 • 0.24
SE80/185S	185 • 7.3	361 • 14.2	208 • 8.2	200 • 7.9	200 • 7.9	170 • 6.7	340 • 13.4	6 • 0.24	8 • 0.31
SE100/185T	185 • 7.3	389 • 15.3	245 • 9.6	245 • 9.6	200 • 7.9	170 • 6.7	340 • 13.4	6 • 0.24	8 • 0.31
SE120/215T	215 • 8.46	389 • 15.3	245 • 9.6	250 • 9.8	215 • 8.5	280 • 11.0	560 • 22.0	6 • 0.24	8 • 0.31
SE130/250T	250 • 9.84	398 • 15.7	254 • 10.0	256 • 10.1	230 • 9.0	280 • 11.0	560 • 22.0	7 • 0.28	10 • 0.39
SE150/215T	215 • 8.46	398 • 15.7	254 • 10.0	260 • 10.2	230 • 9.0	280 • 11.0	560 • 22.0	7 • 0.28	10 • 0.39
SE170/250TC	250 • 9.84	421 • 16.6	230 • 9.1	256 • 10.1	250 • 9.8	300 • 11.8	600 • 23.6	7 • 0.28	10 • 0.39
SE210/250TC	250 • 9.84	478 • 18.8	260 • 10.2	281 • 7.5	250 • 9.8	300 • 11.8	600 • 23.6	7 • 0.28	13 • 0.51
SP240TCi	300 • 11.81	490 • 19.3	266 • 10.5	296 • 11.7	300 • 11.8	300 • 11.8	600 • 23.6	10 • 0.39	13 • 0.51
SP285TCi	300 • 11.81	455 • 17.9	270 • 10.6	310 • 12.2	300 • 11.8	300 • 11.8	600 • 23.6	10 • 0.39	13 • 0.51

Stern thruster (mm • in)	I	II	III _{min}	IV _{max}	V	VI	Tunnel Length
SE30/125S	196 • 7.72	190 • 7.48	135 • 5.31	14 • 0.55	160 • 6.3	217 • 8.5	197 • 7.76
SE40/125S	196 • 7.72	190 • 7.48	135 • 5.31	14 • 0.55	160 • 6.3	217 • 8.5	197 • 7.76
SE60/185S	225 • 8.90	256 • 10.1	150 • 5.91	35 • 1.38	200 • 7.8	300 • 11.8	337 • 13.27
SE80/185S	321 • 13.7	256 • 10.1	200 • 7.87	54 • 2.13	200 • 7.8	300 • 11.8	337 • 13.27
SE100/185T	349 • 4.92	256 • 10.1	200 • 7.87	54 • 2.13	200 • 7.8	300 • 11.8	337 • 13.27
SE120/215T	349 • 4.92	300 • 11.8	215 • 8.46	54 • 2.13	200 • 7.8	300 • 11.8	330 • 13.0
SE130/250T	359 • 14.13	340 • 13.4	250 • 9.84	60 • 2.36	200 • 7.8	350 • 11.8	350 • 13.87
SE150/215T	359 • 14.13	300 • 11.8	215 • 8.46	54 • 2.13	200 • 7.8	350 • 13.8	330 • 13.0
SE170/250TC	382 • 15.04	340 • 13.4	250 • 9.84	60 • 2.36	200 • 7.8	350 • 13.8	350 • 13.87
SE210/250TC	420 • 46.54	360 • 14.2	300 • 11.81	50 • 1.97	200 • 7.8	350 • 13.8	350 • 13.87
SP240TCi	441 • 17.36	420 • 16.5	300 • 11.81	60 • 2.36	258 • 10.2	396 • 15.6	456 • 17.95
SP285TCi	406 • 15.98	420 • 16.5	300 • 11.81	60 • 2.36	258 • 10.2	396 • 15.6	456 • 17.95

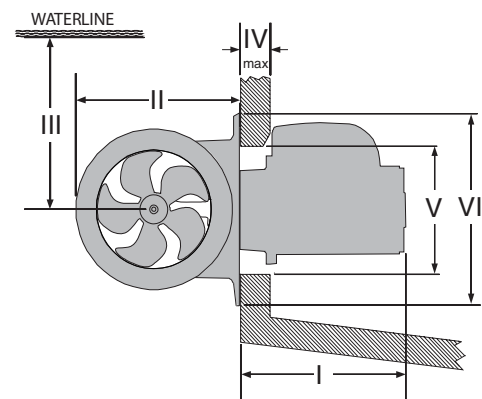

Ignition Protected DC Thrusters

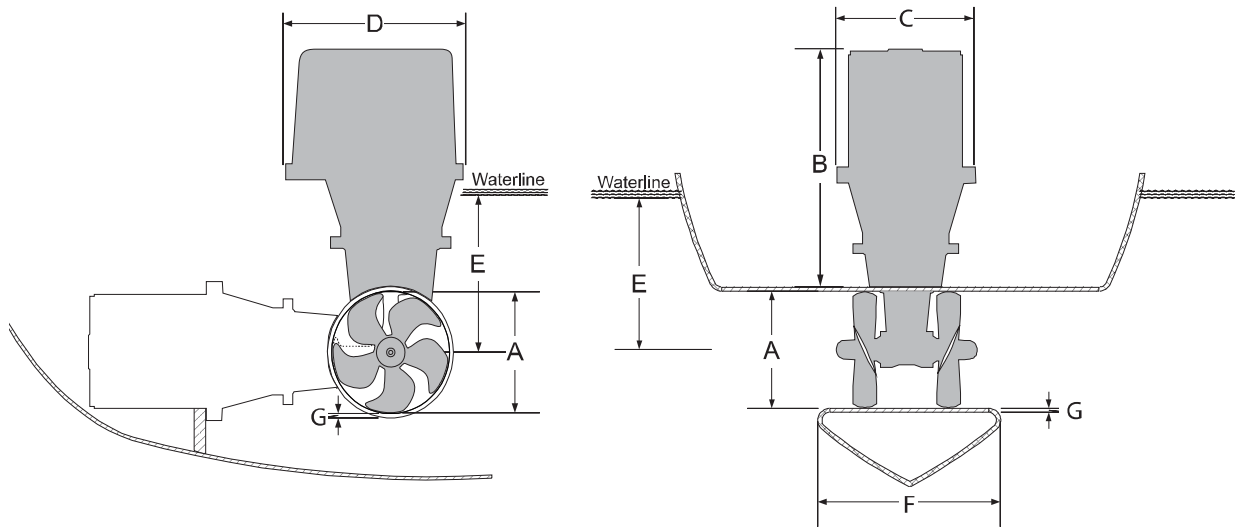

Thruster (mm • in)	A	B	C	D	E _{min}	F	F _{recommended}	G _{min}	G _{max}
SE30/125S IP	125 • 4.92	245 • 9.6	226 • 8.9	230 • 9.1	125 • 4.92	92 • 3.6	184 • 7.25	4 • 0.16	5 • 0.20
SE40/125S IP	125 • 4.92	245 • 9.6	226 • 8.9	230 • 9.1	125 • 4.92	92 • 3.6	184 • 7.25	4 • 0.16	5 • 0.20
SE60/185S IP	185 • 7.3	270 • 10.6	230 • 9.1	272 • 10.7	150 • 5.91	117 • 4.6	234 • 9.2	4 • 0.16	6 • 0.24
SE80/185S IP	185 • 7.3	376 • 14.8	262 • 10.3	327 • 12.9	200 • 7.87	170 • 6.7	340 • 13.4	6 • 0.24	8 • 0.31
SE100/185T IP	185 • 7.3	451 • 17.8	308 • 12.1	382 • 15.0	200 • 7.87	170 • 6.7	340 • 13.4	6 • 0.24	8 • 0.31
SE120/215T IP	215 • 8.46	451 • 17.8	308 • 12.1	382 • 15.0	215 • 8.46	280 • 11	560 • 22.0	6 • 0.24	8 • 0.31
SE130/250T IP	250 • 9.84	451 • 17.8	308 • 12.1	382 • 15.0	230 • 9.00	280 • 11	560 • 22.0	7 • 0.28	10 • 0.39
SE170/250TC IP	250 • 9.84	451 • 17.8	308 • 12.1	382 • 15.0	250 • 9.84	300 • 11.8	600 • 23.6	7 • 0.28	10 • 0.39

Stern thruster (mm • in)	I	II	III _{min}	IV _{max}	V	VI	Tunnel Length
SE30/125S	220 • 8.66	190 • 7.48	135 • 5.1	14 • 0.55	160 • 6.3	217 • 8.5	197 • 7.76
SE40/125S	220 • 8.66	190 • 7.48	135 • 5.31	14 • 0.55	160 • 6.3	217 • 8.5	197 • 7.76
SE60/185S	265 • 10.43	256 • 10.1	150 • 5.91	35 • 1.38	200 • 7.8	300 • 11.8	337 • 13.27
SE80/185S	399 • 15.70	256 • 10.1	200 • 7.87	54 • 2.13	200 • 7.8	300 • 11.8	337 • 13.27
SE100/185T	407 • 16.02	256 • 10.1	200 • 7.87	54 • 2.13	200 • 7.8	300 • 11.8	337 • 13.27
SE120/215T	407 • 16.02	300 • 11.8	215 • 8.46	54 • 2.13	200 • 7.8	300 • 11.8	330 • 13.00
SE130/250T	407 • 16.02	340 • 13.4	250 • 9.84	60 • 2.36	200 • 7.8	350 • 13.8	350 • 13.87
SE170/250TC	407 • 16.02	340 • 13.4	250 • 9.84	60 • 2.36	200 • 7.8	350 • 13.8	350 • 13.87



Retractable Thrusters

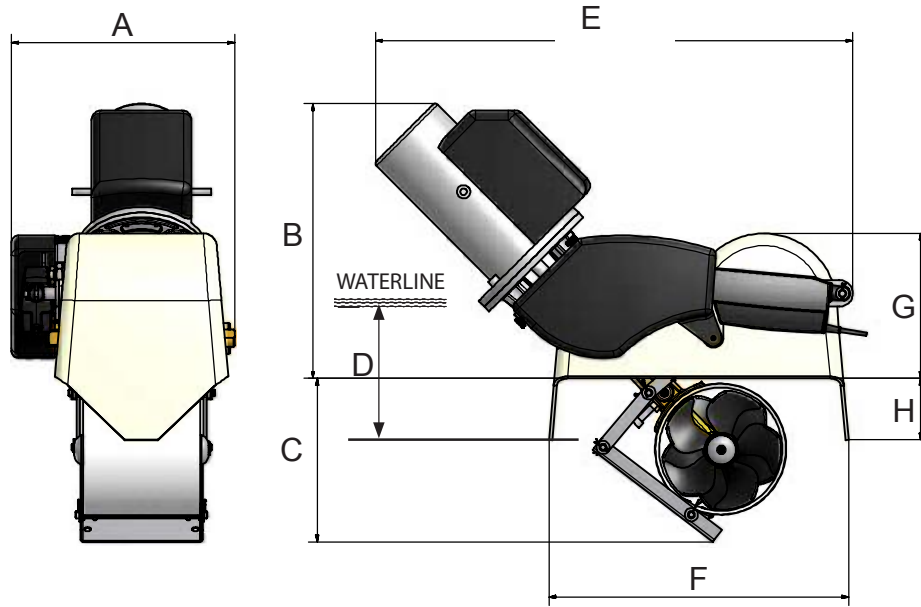

Thruster (mm • in)	A	B	C	D _{min}	E	F	G	H
SR80/185T	335 • 13.2	413 • 16.3	245 • 9.6	185 • 7.3	716 • 28.2	450 • 17.7	218 • 8.6	92 • 3.6
SR100/185T	335 • 13.2	460 • 18.1	245 • 9.6	185 • 7.3	745 • 29.3	450 • 17.7	218 • 8.6	92 • 3.6

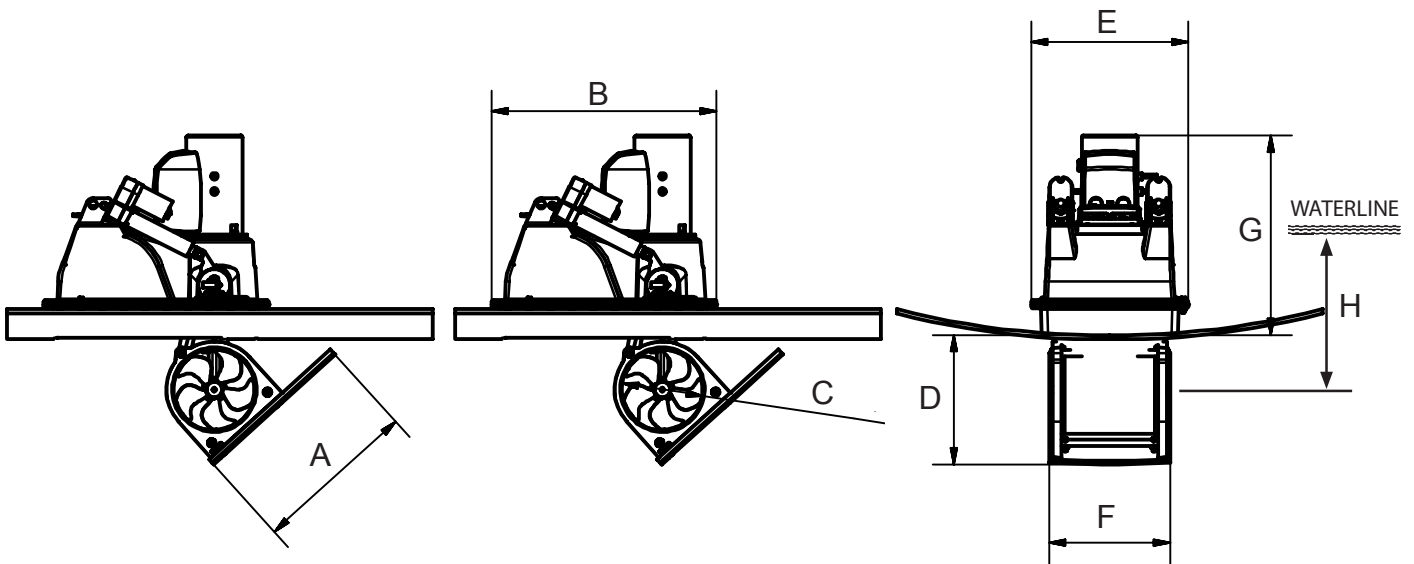

Thruster (mm • in)	A	B	C	D	E	F	G	H _{min}
SR130/250T	500 • 19.7	688 • 27.1	Ø250 • 9.8	395 • 15.6	480 • 18.9	370 • 14.7	594 • 23.4	250 • 9.8
SR170/250TC	500 • 19.7	688 • 27.1	Ø250 • 9.8	395 • 15.6	480 • 18.9	370 • 14.7	609 • 24.0	250 • 9.8
SR210/250TC	500 • 19.7	688 • 27.1	Ø250 • 9.8	395 • 15.6	480 • 18.9	370 • 14.7	694 • 27.3	250 • 9.8



External stern thruster

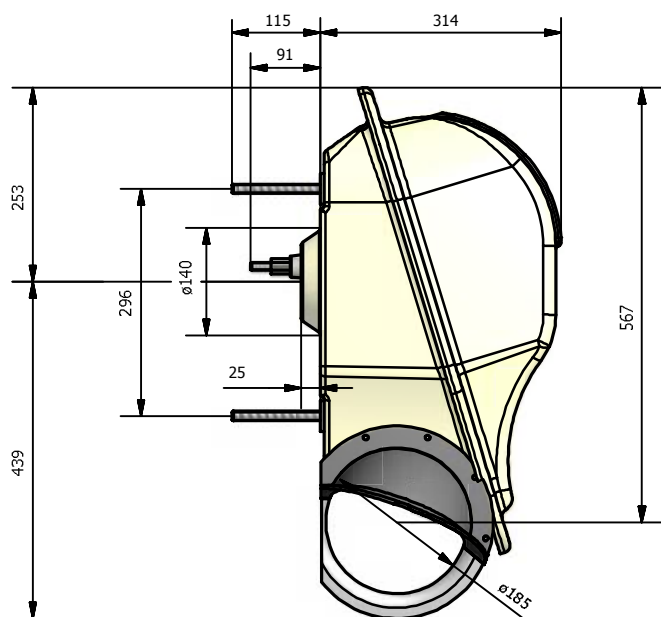

Max. stern thickness: 100mm (80mm recommended)

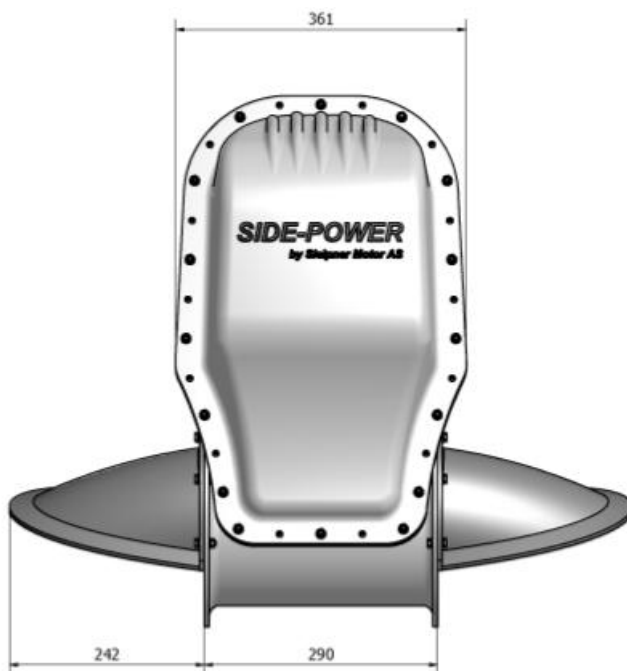

Accessories

PJC 211/212/221/222

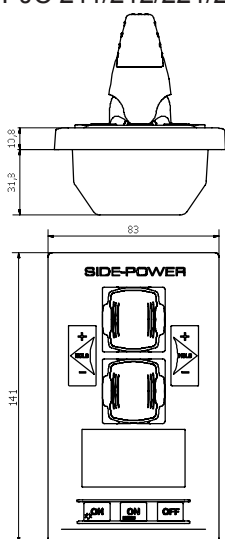

PPC 800

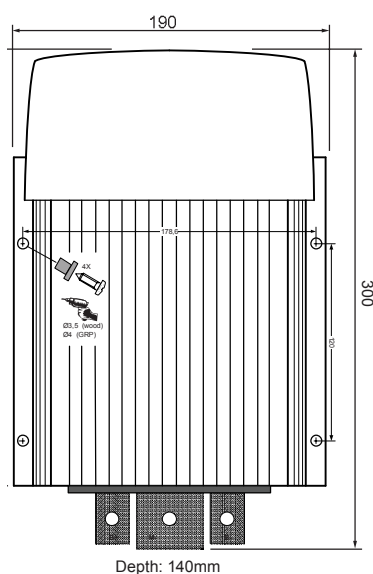

Touch panel 8950G
Single joystick panel 8960G
S-linkTouch panel 8700

H:70mm
W:70mm

Round touch panel 8955G
Boat switch panel 8965G

\varnothing :86.5mm

Dual joystick panel 8940G
Docking panel 8909

H:120mm
W:70mm



Other products

Other catalogues available:



Steering Systems



Stabilizer Systems



Hydraulic Systems



Superyacht Products

There is a limit to the power you can practically generate with DC electrical systems, so for super yachts and other larger, heavier vessels DC thrusters are rarely an option.

Larger thruster models and extended run time make hydraulic thrusters the ideal choice for commercial crafts and other less maneuverable yachts. In conjunction with a good hydraulic system these thrusters offer continuous operation and you can get variable speed control with proportional control and valves. The last generation hydraulic thruster systems features the S-link control system with two way communication, opening for a whole new range of features.

With models from 100 to 1400kg of thrust for use as either bow or stern thrusters, Side-Power has suitable models for a wide variety of yachts and commercial vessels. To ensure matching quality of all components in a hydraulic thruster system, we also offer complete hydraulic systems with guaranteed performance and reliability.

Please see the separate hydraulic system brochure or ask your dealer for more details.



Hydraulic thruster systems



For many vessels, a hydraulic system offers an economic advantage because of the possibility to run several systems onboard from a centralized hydraulic power source. This will save cost on the individual components so that the complete package ends up with a more favorable cost compared to running all items with individual DC electric motors. Equipment that is often powered by a centralized hydraulic system includes windlasses, stabilizers, winches, cranes, furling systems and lifting mechanisms etc.

There are many different ways of designing hydraulic systems, and some solutions are better for specific applications than others. Side-Power hydraulic systems are designed to provide outstanding performance and flexibility to efficiently support any on-board hydraulic equipment that is sensible to power from a centralized hydraulic system.



Stabilizer systems



- Increased comfort on board
 - More use of the boat as you can go out in more weather conditions
 - Less wear and tear of the boat as you do not have to always head into or away from larger waves to avoid people onboard becoming seasick by the uncomfortable rolling motion
- Less overall fuel consumption
 - While adding fins (or other types) basically will increase the fuel consumption a little at the same speed, our claim is that the overall fuel consumption will be reduced
 - You can take the direct route to where you wish to go even in rough conditions
 - You can go at a lower speed with the waves from the side while still being comfortable (modern cruisers have less roll at higher speeds, thereby people often drive them hard to avoid the rolling)



Steering systems



In addition to traditional hydraulic steering systems and electro-hydraulic power steering systems, Side-Power has also developed a Superyacht-specific steering system. While designing this, we have been able to draw from almost 100 years of experience with steering systems, and from our extensive knowledge on hydraulic systems.

The Side-Power Superyacht Steering is a RINA-classed system which fills all demands to a commercial grade steering system.

The Superyacht steering control system is a “fly-by-wire” system based around the same S-link bus as the Thruster and Stabilizer systems - the difference is that in the Steering System everything is made with dual configurations, to meet the required redundancy level. This dual configuration extends to the mechanical and hydraulic side of the system as well.

The Superyacht Steering can be operated from a traditional helm or by joystick and the system is ready for autopilot interfacing.



Less noise - more thrust!

Upgrade your Side-Power with the new 5-bladed Q-prop.

- 20 - 40% noise reduction *
- Complete upgrade kits available
- Increased thrust
- Easy mounting
- Great value!



* Actual noise reduction will vary with boat type and thruster installation.



Worldwide sales and service



www.side-power.com



SAILTEC Projekt GmbH
Hasselbinnen 28
D-22969 Schenefeld

+49 40 822994-0
info@sailtec.eu
www.sailtec.eu