

# HYDRAULIC THRUSTER SYSTEMS



SAILTEC Projekt GmbH  
Hasselbinnen 28  
D-22969 Schenefeld

+49 40 822994-0  
info@sailtec.eu  
www.sailtec.eu

## CONFIDENCE BY CONTROL



SIDE-POWER  
Thruster Systems



# SIDE-POWER Hydraulic systems

A hydraulic thruster system is the natural choice when extensive thruster usage or long run cycles are required. We design our hydraulic systems with the style needed for pleasure craft and the reliability necessary for commercial use.

For many vessels, a hydraulic system offers an economic advantage because of the possibility to run several systems onboard from a centralized hydraulic power source. This will save cost on the individual components so that the complete package ends up with a more favorable cost compared to running all items with individual DC electric motors. Equipment that is often powered by a centralized hydraulic system includes windlasses, stabilizers, winches, cranes, furling systems and lifting mechanisms.

There are many different ways of designing hydraulic systems, and some solutions are better for specific applications than others. Side-Power hydraulic systems are designed to provide outstanding performance and flexibility to efficiently support any on-board hydraulic equipment that it makes sense to power from a centralized hydraulic system.

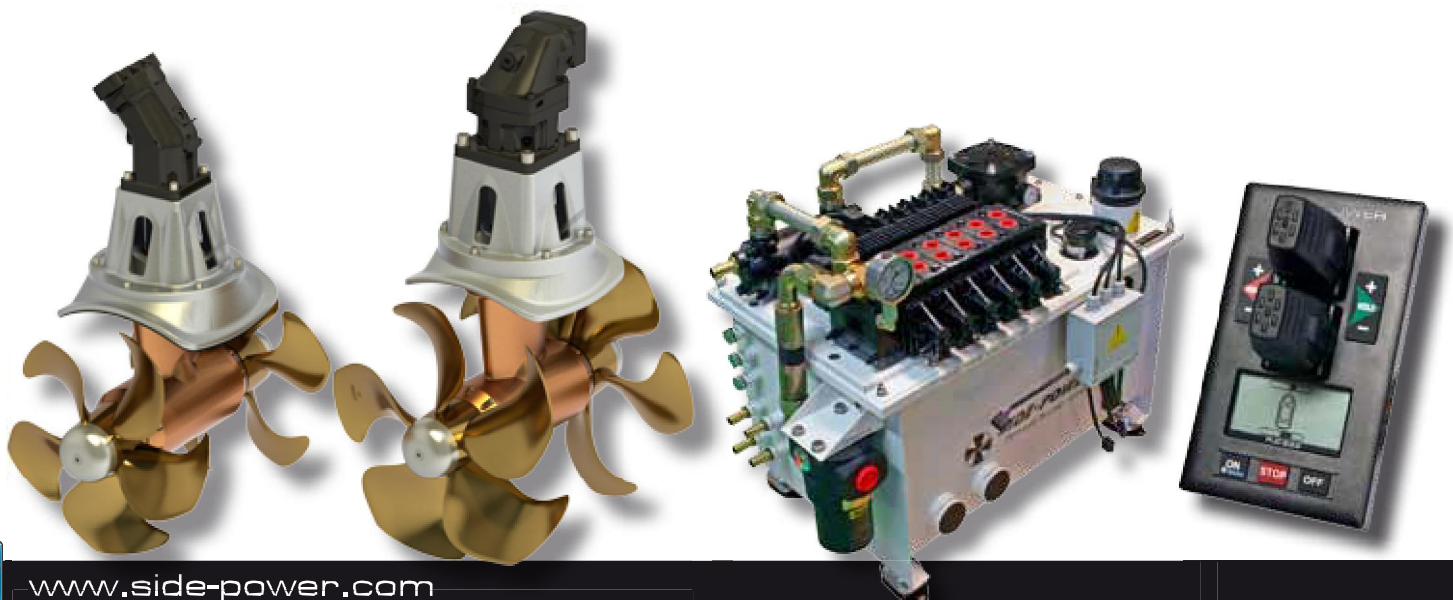
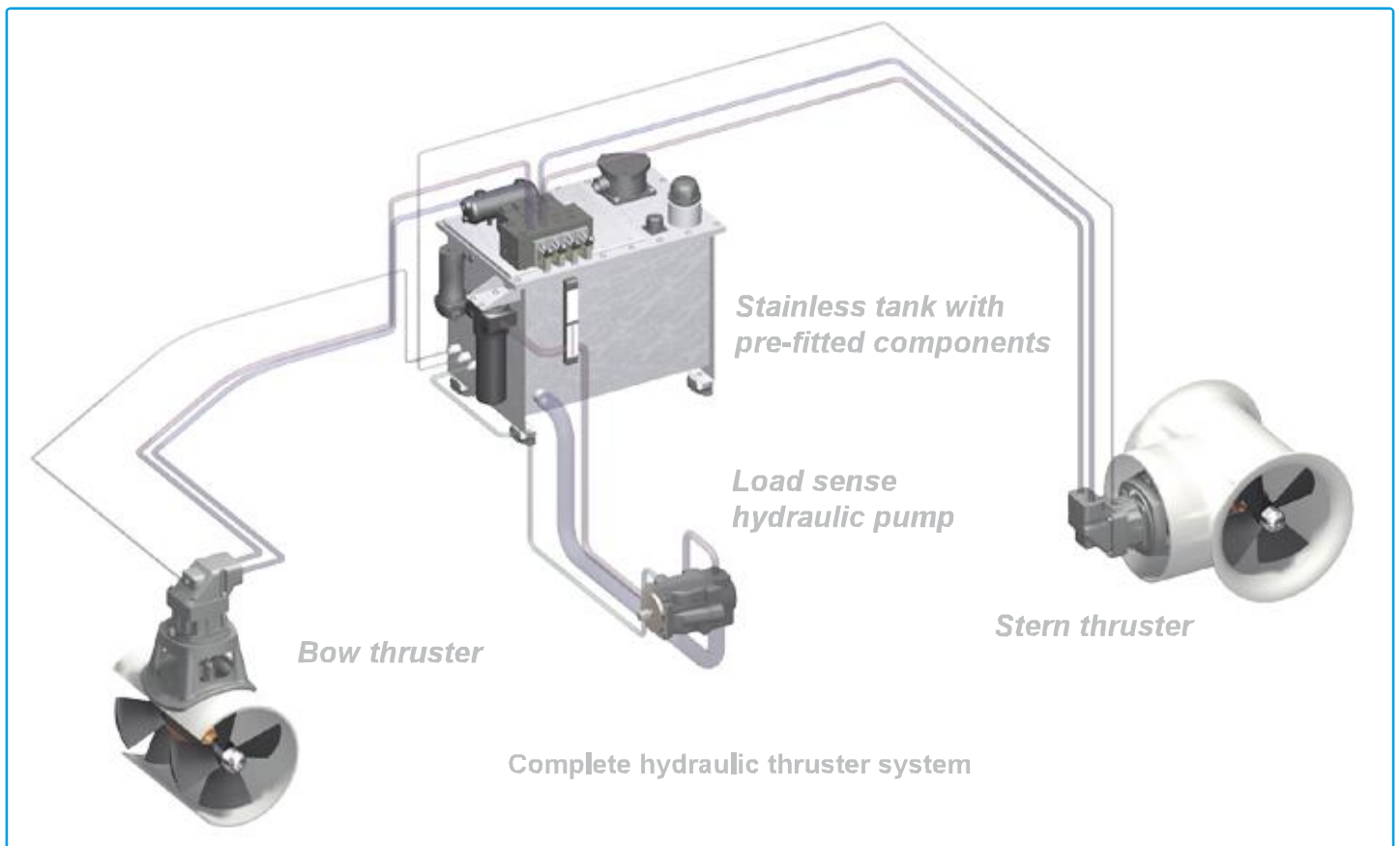

The leading position of Side-Power thrusters is a clear result of focus on the products performance, functionality and reliability.

For many years Side-Power has been the one brand that others have tried to copy, but through extensive research and development we have remained ahead of the pack.

Over the last ten years we have evolved into the Commercial and Superyacht sectors with the SP550 thruster, allowing us to gain the necessary experience to satisfy these sectors. One point that makes us different from many of the traditional suppliers found in the Commercial and Superyacht industry is that we develop a high quality product extremely efficiently. This comes from our experience in making thousands of smaller thrusters a year for the production builders around the world. The production markets demand high quality and reliable products with an eye on cost effectiveness. We focus on investing in the development of products with the efficiency of volume in mind.

Many of the leading Yacht Builders worldwide use our complete hydraulic systems for models up to 30m (100ft). The quality and performance of these products improves with constant product development. As the size of yachts has increased so has our product offering with the SH1000 and the SH1400 for hydraulic based systems and thrusters for AC based systems with up to 1400kg of thrust.

## SH1000 & SH1400

The SH1000 delivers up to 1000 kg (2205lbs) of thrust from a 20 inch tunnel while the SH1400 delivers up to 1400 kg (3086lbs) from a 24 inch tunnel.

Both the SH1000 and the SH1400 are type approved by Det Norske Veritas and comply with all other shipping standards. As with all other Side-Power systems, they can be controlled using the S-Link system thus benefiting from all the advantages of a bus based digital control system. The S-link system also has the benefit that one single control bus can be used to control a mixed system with Side-Power hydraulic thrusters, Side-Power AC thrusters and stabilizers.

### ▶ Electric or hydraulic?

Being a leading manufacturer of both hydraulic, AC and DC electric thruster systems, you can trust Side-Power to give you objective advice on what to choose for your vessel.

We have the knowledge and experience. Our philosophy is to make sure things are done right and customers are fully satisfied.

### ▶ Continuous use

A Side-Power hydraulic thruster system is designed for continuous run capability.

### ▶ Controlled power

With a Side-Power hydraulic system, you can easily, and without excessive cost get proportional control of your thruster(s). This will provide an easier and more precise control of the vessel in varying conditions.

### ▶ Stern thruster

The added cost for fitting a sternthruster for your vessel is sometimes only a modest percentage of the total package if you are already installing a complete hydraulic system.

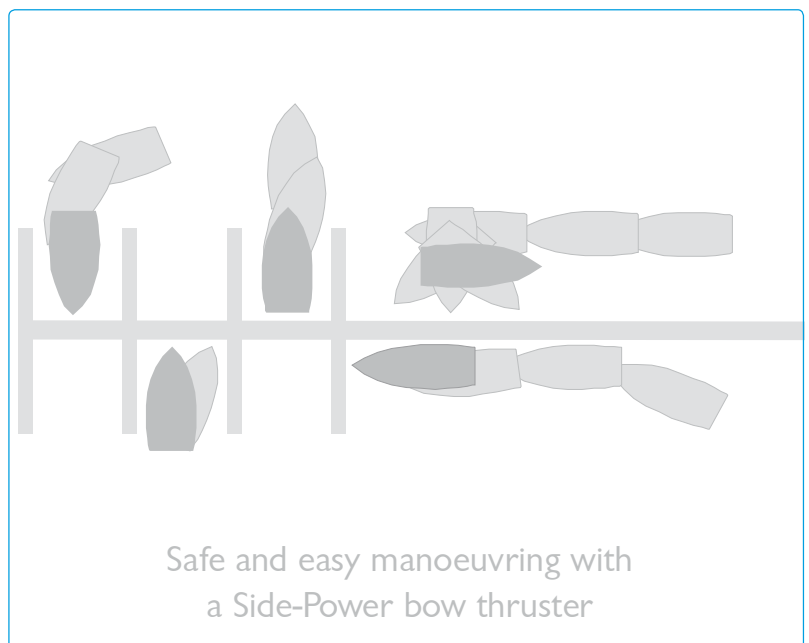
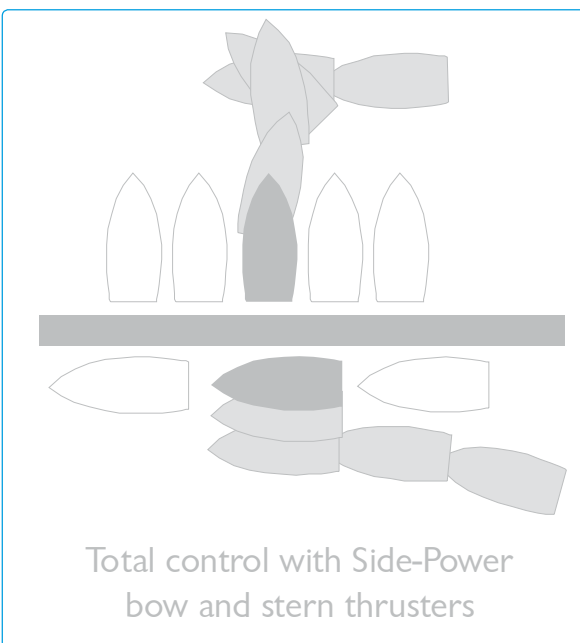

# SIDE-POWER

Side-Power thrusters are the choice of the leading boat manufacturers around the world. Our engineering and development work is the foundation for the high quality products that have been accepted as the best in the industry.

## Safety

Side-Power thrusters include several features to ensure the safety of your vessel and its passengers. These features protect against technical and operator faults.

- mechanical protection of drive gear with flex couplers
- electronic protection against sudden change of drive direction
- protection against accidental operation incorporated in control panels

For more information about the protection of the hydraulic system, please see page 6/7

## Performance

Investing in product development and testing is an important reason why Side-Power is the leading thruster brand today. Now larger vessels can benefit from these investments that have resulted in modern, cost effective production of highly efficient and reliable thrusters.

- propulsion technology know-how
- 5-bladed composite or NiBrAl propellers
- improved water flow from streamlined gear leg design
- high thrust and efficiency in compact tunnel diameters
- all hydraulic components are supplied by high quality manufacturers like Parker Hannifin, Sauer Danfoss, Bosch Rexroth and Bowman

## Reliability

The world's leading boatbuilders have used Side-Power for many years because they know they can trust Side-Power equipment to work without problems, year after year.

- in-house manufacturing and assembly
- engineering assisted by experience
- use of superior materials
- controlled quality of every supplied part
- Worldwide product support
- 2-year limited warranty



Through our close cooperation with major boatbuilders we know how important an easy and proper installation is. Our hydraulic thruster systems are designed to install easily.

## Installation

Side-Power hydraulic systems are designed for ultimate reliability, performance and easy installation. For the installer, perhaps the most important feature of any hydraulic system is that they are delivered ready for installation. Side-Power hydraulic systems are manufactured with this in mind and each hydraulic system is tailored specifically to each vessel and its specific needs. Side-Power hydraulic systems come pre-fitted with all internal hydraulic and electrical components ensuring correct installation and potentially saving hours of work for the installer. Side-Power systems do require the installation of external hydraulic and electrical connections, which can only be done onboard.

## Brand name components

Side-Power hydraulic systems use only brand name hydraulic components ensuring reliability and easy worldwide access to spare parts and service.

## Full documentation

A Side-Power hydraulic system is delivered with all necessary drawings, installation manual, system startup manual, service manuals, hose/pipe specifications etc. to ensure an easy and correct installation and a lifetime of reliability and serviceability.

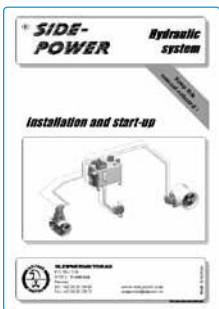

Installation and start-up manual



System manual

## Side-Power hydraulic system features

- compact-sized units
- "Plug & Go" electric wiring
- all hydraulic connections internally on the tank are pre-fit
- delivered ready with all hydraulic settings
- all electric connections are pre-wired for thrusters on tank
- full documentation, including installation and user manual, startup manual etc.
- fast and safe propeller mounting with locknut
- easy access anodes



## ▶ The safe choice

Side-Power is a reliable, long term partner because we have design, manufacturing, product support and service directly in house. This means that you always get up to date products you can rely on year after year.

## ▶ Technology

The most important factor for correct sizing of a thruster as well as designing the hydraulic system to power it, is to have exact and detailed knowledge about the thruster's performance and power requirements. All Side-Power thrusters have specially developed and tested composite or NiBrAl propellers for maximum performance. We supply matched hydraulic systems to your requirements to ensure ultimate cost and space efficiency.



# Hydraulic system components

## TANK

To ensure a long life and trouble-free operation of your thruster system, choose the compact Side-Power hydraulic system for your hydraulic power needs.

A thruster will normally be the most demanding consumer among the hydraulic parts onboard, so it is important that the system be correctly built and sized. A Side-Power hydraulic system is specifically designed for ultimate flexibility to support any of the other hydraulic parts on board. It has been designed using the same stringent standards as all other Side-Power parts, focusing on:

- Reliability
- Safety
- Performance
- Easy & safe installation
- Easy maintenance

Perhaps the most important feature of any complete hydraulic system is for it to be delivered as ready as possible for installation. Side-Power systems require only the external hydraulic and electrical connections (which can only be done onboard), saving time and trouble for the installers.

A Side-Power system is delivered with all necessary drawings, installation manuals, system startup manual, service manuals etc. to ensure an easy and correct installation and a lifetime of reliability and serviceability.

### Cooling and filtration

It is important for the lifetime and reliability of a hydraulic system that the oil stays clean and within accepted temperatures to avoid excessive wear and damage to any of the components in the system. The Side-Power hydraulic system is designed to achieve this by having:

- A Dual internal oil cooler (optional)\*
- B Air filter in ventilation cap
- C High pressure filter with service gauge
- D Return filter with service gauge
- E Oil fill with filter
- F Additional oil cooler for extra cooling requirements (optional)\*

\* an optional hydraulic driven water pump for the oil cooler is also available

### Information and warning system

For safety and ease of service there are several sources of information and warnings on the tank.

- A Oil level and temperature gauge on the tank
- B Electric alarm outputs for oil level and temperature to Side-Power control panels with alarm lights and sound
- C Both filters have gauges that indicate the condition of their filters and when they need changing
- D Pressure gauge on valve shows oil pressure from pump

### Valve system

- Safety relief valve on feed protects system against overpressure
- Can be built to control of up to seven hydraulic units onboard
- Individual pressure and flow adjustments (preset) for all components
- Shock valve on outputs to all components
- Hydraulic flow curve specialized on thruster modules to match propellers thrust curves (proportional controlled systems)
- Manual activation of each consumer for easy servicing and trouble shooting
- Identification of each valve system for reference to factory specifications



### ▶ Tank features

- Powder coated stainless steel
- Soft mounting feet to avoid structural carried noise on floor mounted tanks
- Internal swash plate that also helps remove air from the oil
- Angled bottom of tank with drain plug at lowest point on floor mounted tanks
- All internal hydraulic connections on tank are pre-fitted
- All internal electric connections for thrusters pre-wired, ready with extension connectors
- Optional temperature controlled water pump for oil cooler



# Hydraulic system components

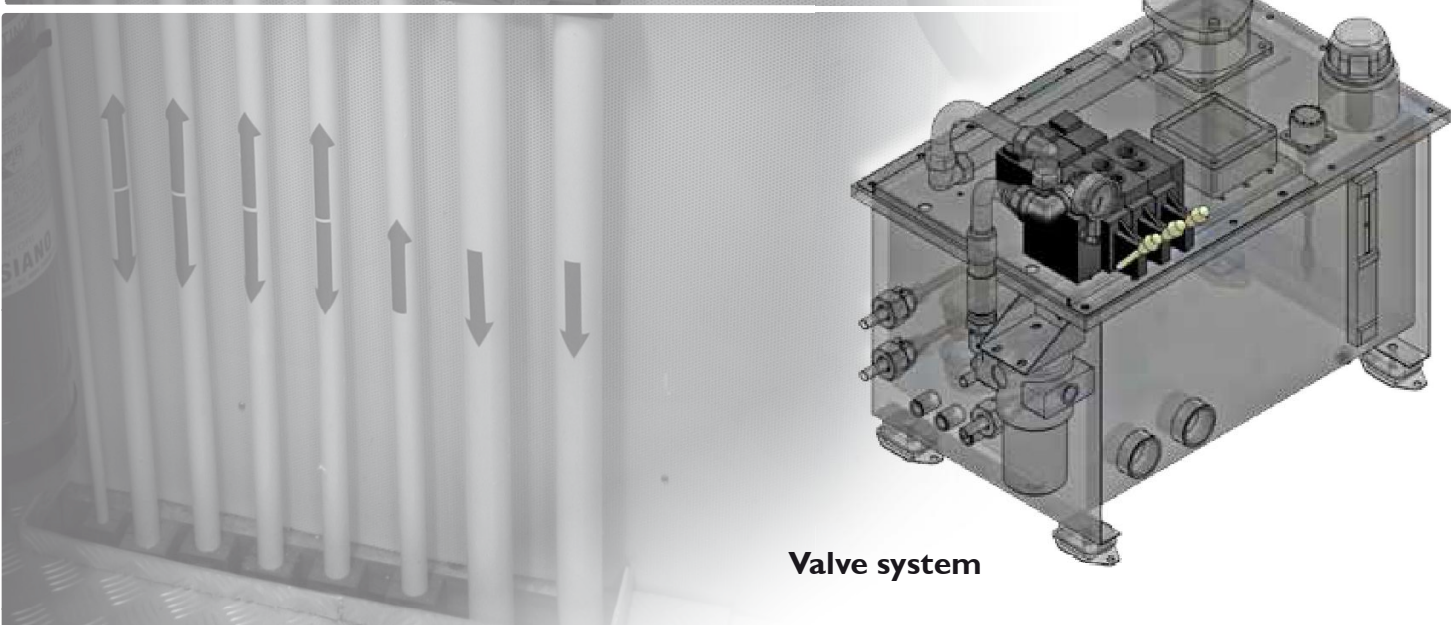
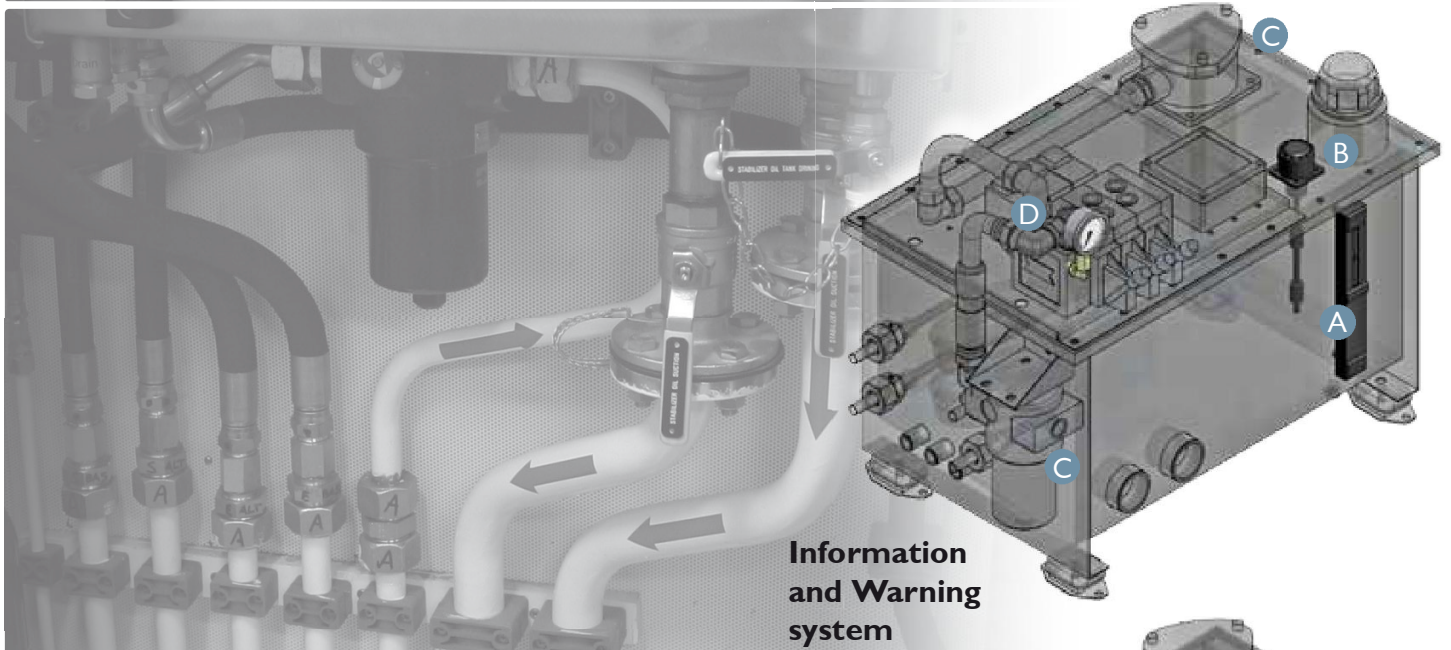
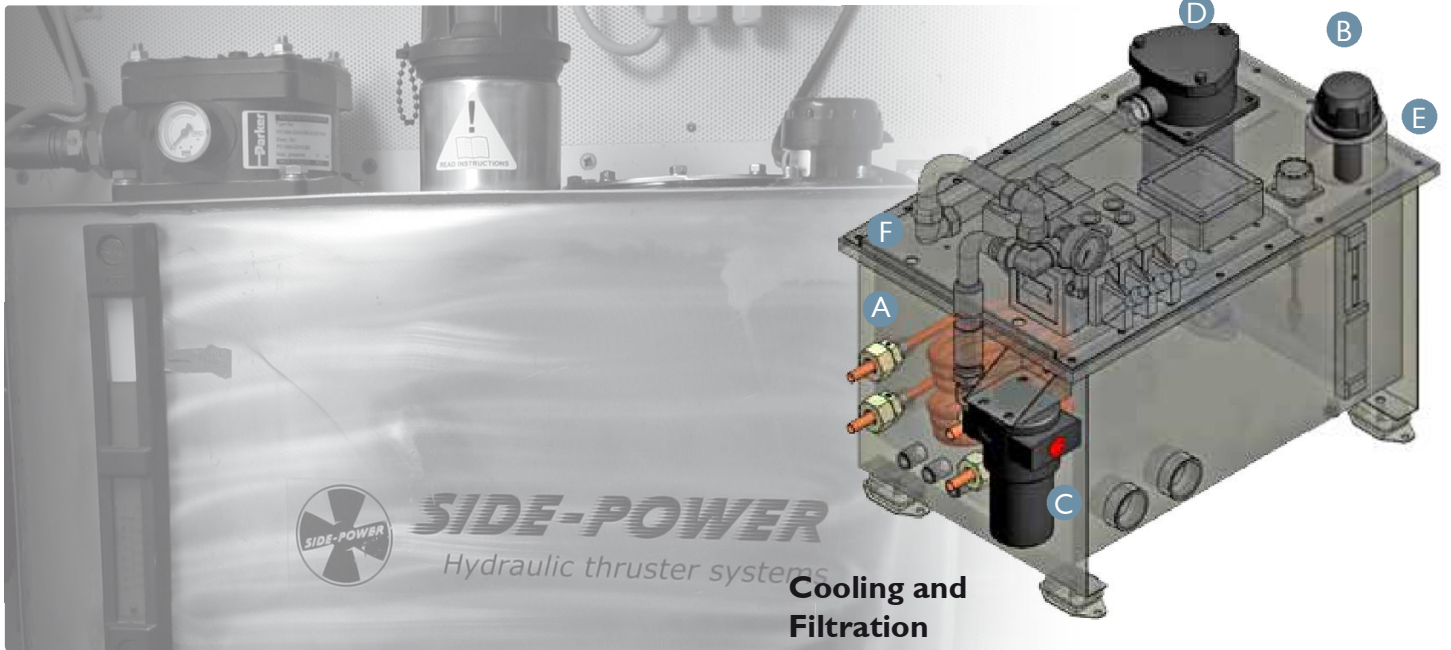

# Hydraulic system components

## PUMPS

Side-Power hydraulic systems use almost exclusively variable displacement load sense pumps. They offer a high level of reliability, efficiency and flexibility without generating unnecessary noise or the need for huge tanks and oil cooling systems.

### Powering a thruster system

A thruster is almost always the most power demanding part of a hydraulic system. That's why the hydraulic system must be dimensioned to the thruster(s). Knowing our thrusters better than anybody, we can design the perfect hydraulic system to match.

### Advantages with load sense system

- Reliable and well proven system
- Delivers only the flow and pressure that is actually needed at the time
- The load sense control of the pump is more reliable than an electric clutch
- Low heating and energy waste
- High efficiency piston pumps
- Low noise in both running and standby mode
- Ignition protected for fitting in gas/petrol areas

### Normal power sources for hydraulic pumps

- Main engines / gear box
- Generator / auxiliary engines
- AC electric motor



*One of many variable displacement load sense pumps offered by Side-Power*

### ► What is «load sense»

Load sense means that the pump's displacement is hydraulically controlled by the hydraulic valve adjusting its "swash plate". The valve will continuously sense if there is a need for more flow or pressure to any consumer and adjust the pump accordingly. This means there is no need to rely on electrical activation or to have large volumes of oil pumped around the boat constantly.

### How to connect and power hydraulic pumps

The most common way of fitting pumps is by a PTO (Power Take Off). This is the preferred method if available, because everything is then matched together by standards so that the fitting is safe and reliable. If there is no PTO available, it is normally possible to fit the pump with a bracket and a flexible coupling to the front end of any engine. Some also use belt drives, but we prefer not to do so because of the high torque needed by a thruster system. Another option is to power the hydraulic pump by using an AC electric motor. Below you can see some examples of these installation methods.

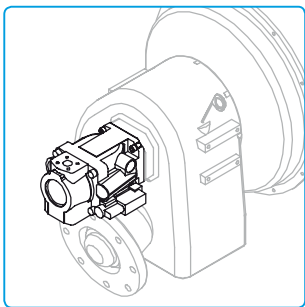

*PTO fitting of pump*

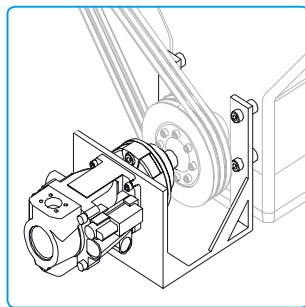

*Engine front-end fitting of pump*

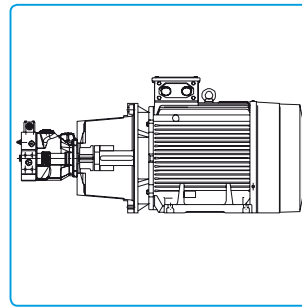

*AC Power pack*



## THRUSTERS



The 5 blade special skew propellers are the result of over 2 years of development work and thousands of tests. They have been designed to reduce the noise level, while maintaining the exceptional efficiency of the old 4 blade Side-Power propellers. This goal was achieved, and we even chose to make a little bit more aggressive on some models, increasing the thrust on most thrusters. Please see individual information on each new thruster for more details.



- Noise reductions of up to 75% measured in controlled environments
- The expected and tested normal noise reduction in “average installations” 20-40%



The thruster gearleg is filled with oil from a remote reservoir located above the waterline. This generates overpressure, making an effective seal against water intrusion in the gear leg.

- Separate oil reservoir placed above the waterline.
- Allows easy access for oil changes
- Having the advantage to be able to change oil in units used commercially, with hundreds of running hours per year.



Sealed gear leg with long-life “mechanical” seal where highly polished ceramic and carbon surfaces form the only moving sealing surfaces, ensuring protection against damaging water intrusion into the gear leg. Pre-filled with special gear oil for lifetime lubrication.

- “Mechanical” seals with surfaces of ceramic and carbon for ultimate security against water intrusion



### TWIN PROPELLERS:

The twin propeller system can give more thrust than a single propeller system in the same tunnel diameter. This is our choice for our mid-range models where high thrust is required in a small tunnel diameter. Due to the compact design and high performance, the twin models have become the thrusters of choice among boat builders around the world.



### TWIN COUNTER ROTATING PROPELLERS:

Two counter-rotating propellers can give the most thrust at a good performance ratio in a minimal tunnel diameter. This system is used in our larger thrusters for maximum power. The TC models are the favourite thrusters among leading boat builders for their high-end yachts.



∅ 185 mm



∅ 215 mm



∅ 250 mm



∅ 300 mm



∅ 386 mm



With the ever growing demand for increased performance, we continue to expand our offering of tunnel diameters to allow customers to choose more powerful thrusters in tunnel sizes that will fit in their boat.

### Facts about tunnel sizes:

- Principally a larger tunnel diameter will always be more energy efficient than a smaller tunnel diameter for the same thrust. The factor is water speed, and this is decided by the amount of water you move through the possible opening which is the square area of the tunnel less the area blocked by the thrusters gearleg.
- The opening in the boat hull is not only the circular size of the tunnel diameter. Because the hull is angled, you get a much larger oval opening, and this makes a larger tunnel diameter more difficult to fit properly into the hull.

∅ 513 mm

∅ 610 mm

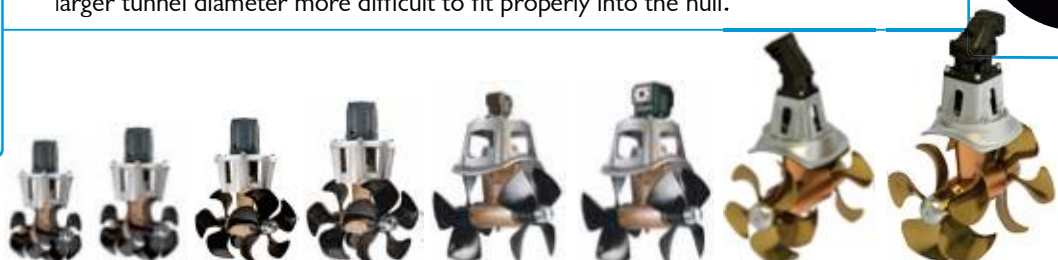

# Technical specifications



## SH 100/185 T



Light duty thrust up to <sup>(kg • lbs)</sup>	100 • 220
Heavy duty thrust up to <sup>(kg • lbs)</sup>	80 • 176
Typical boat size (ft • m)	30' - 34' • 9 - 16
Tunnel I.D. (mm • in)	185 • 7.28"
Propulsion system	Twin
Hydraulic power up to <sup>(kw • Hp)</sup>	6.9 • 9.3
Weight (kg • lbs)	9.0 • 19.8
<b>Item Code</b>	<b>SH100/185T-xxx</b>

### Measurements

A (mm • in)	185 • 7.28
B (mm • in)	195 • 7.64
B max (mm • in)	212 • 8.34
C min. (mm • in)	200 • 7.87
D (mm • in)	170 • 6.70
D recommended (mm • in)	340 • 13.4
E min. (mm • in)	6 • 0.24
E max. (mm • in)	8 • 0.31

### Stern Thrusters

F (mm • in)	172 • 76.72
G (mm • in)	256 • 10.08
C min. (mm • in)	150 • 5.91
H max. (mm • in)	35 • 1.38
Tunnel length (mm • in)	337 • 13.27

### Item code

<b>Stern thruster kit</b>	<b>90086i</b>
<b>Cowls - short model</b>	<b>90075</b>
<b>Cowls - long model</b>	<b>90077</b>



## SH 160/215 T



Light duty thrust up to <sup>(kg • lbs)</sup>	160 • 352
Heavy duty thrust up to <sup>(kg • lbs)</sup>	140 • 308
Typical boat size (ft • m)	35' - 62' • 11 - 19
Tunnel I.D. (mm • in)	215 • 8.46"
Propulsion system	Twin
Hydraulic power up to <sup>(kw • Hp)</sup>	10.0 • 13.4
Weight (kg • lbs)	10.5 • 23
<b>Item Code</b>	<b>SH160/215T-xxx</b>

### Measurements

A (mm • in)	215 • 8.46
B (mm • in)	195 • 7.64
B max (mm • in)	230 • 9.05
C min. (mm • in)	215 • 8.5
D (mm • in)	280 • 11
D recommended (mm • in)	560 • 22
E min. (mm • in)	6 • 0.24
E max. (mm • in)	8 • 0.31

### Stern Thrusters

F (mm • in)	172 • 76.72
G (mm • in)	300 • 11.8
C min. (mm • in)	215 • 8.46
H max. (mm • in)	54 • 2.13
Tunnel length (mm • in)	330 • 13

### Item code

<b>Stern thruster kit</b>	<b>90135i</b>
<b>Cowls</b>	<b>90136</b>



## SH 240/250 TC



Light duty thrust up to <sup>(kg • lbs)</sup>	240 • 528
Heavy duty thrust up to <sup>(kg • lbs)</sup>	220 • 440
Typical boat size (ft • m)	42' - 75' • 13 - 23
Tunnel I.D. (mm • in)	250 • 9.8"
Propulsion system	Twin Counter rot.
Hydraulic power up to <sup>(kw • Hp)</sup>	14.9 • 20.0
Weight (kg • lbs)	15.9 • 35.0
<b>Item Code</b>	<b>SH240/250TC-xxx</b>

### Measurements

A (mm • in)	250 • 9.84
B (mm • in)	213 • 8.38
B max (mm • in)	230 • 9.05
C min. (mm • in)	230 • 9.0
D (mm • in)	280 • 11
D recommended (mm • in)	560 • 22
E min. (mm • in)	7 • 0.28
E max. (mm • in)	10 • 0.39

### Stern Thrusters

F (mm • in)	91 • 7.52
G (mm • in)	340 • 13.39
C min. (mm • in)	250 • 9.84
H max. (mm • in)	60 • 2.36
Tunnel length (mm • in)	350 • 13.78

### Item code

<b>Stern thruster kit</b>	<b>90140i</b>
<b>Cowls</b>	<b>90132</b>



## SP 300 HYD



Light duty thrust up to <sup>(kg • lbs)</sup>	300 • 660
Heavy duty thrust up to <sup>(kg • lbs)</sup>	270 • 594
Typical boat size (ft • m)	55' - 100' • 17 - 31
Tunnel I.D. (mm • in)	300 • 11.8"
Propulsion system	Twin Counter rot.
Hydraulic power up to <sup>(kw • Hp)</sup>	17.4 • 23.3
Weight (kg • lbs)	19.5 • 42.9
<b>Item Code</b>	<b>SP300HYD-xxx</b>

### Measurements

A (mm • in)	300 • 11.81
B (mm • in)	220 • 8.66
B max (mm • in)	244 • 9.61
C min. (mm • in)	300 • 11.81
D (mm • in)	300 • 11.81
D recommended (mm • in)	600 • 23.6
E min. (mm • in)	10 • 0.39
E max. (mm • in)	10 • 0.39

### Stern Thrusters

F (mm • in)	195 • 7.68
G (mm • in)	420 • 16.54
C min. (mm • in)	300 • 11.81
H max. (mm • in)	60 • 2.36
Tunnel length (mm • in)	456 • 17.95

### Item code

<b>Stern thruster kit</b>	<b>90200i</b>
<b>Cowls</b>	<b>90220</b>

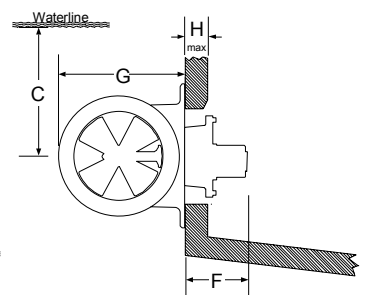
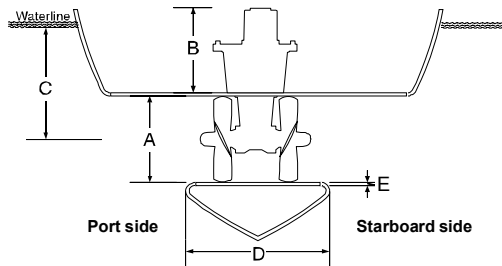
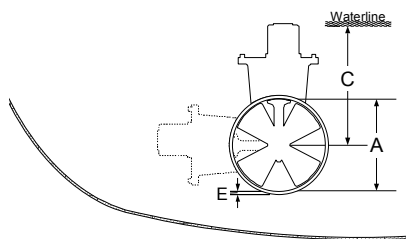

## SH 420/386 TC



Light duty thrust up to (kg • lbs)  
 Heavy duty thrust up to (kg • lbs)  
 Typical boat size (ft • m)  
 Tunnel I.D. (mm • in)  
 Propulsion system  
 Hydraulic power up to (kw • Hp)  
 Weight (kg • lbs)

420 • 925  
 380 • 835  
 75 - 110' • 22 - 35  
 386 • 15.2"  
 Twin Counter rot.  
 29.7 • 39.8  
 51.8 • 114.2

### Measurements

A (mm • in) 386 • 15.2  
 B (mm • in) 292 • 11.5  
 B max (mm • in) 372 • 14.65  
 C min. (mm • in) 380 • 15.0  
 D (mm • in) 500 • 19.7  
 D recommended (mm • in) 750 • 29.5  
 E min. (mm • in) 10 • 0.39  
 E max. (mm • in) 15 • 0.59

**Item Code**

**SH420/386TC-xxx**

### Stern Thrusters

F (mm • in) 257 • 10.12  
 G (mm • in) 540 • 21.25  
 C min. (mm • in) 380 • 15.00  
 H max. (mm • in) ∞  
 Tunnel length (mm • in) 550 • 21.65

### Item code

**Stern thruster kit** 90550  
**Cowls** 90560

## SH 550/386 TC



Light duty thrust up to (kg • lbs)  
 Heavy duty thrust up to (kg • lbs)  
 Typical boat size (ft • m)  
 Tunnel I.D. (mm • in)  
 Propulsion system  
 Hydraulic power up to (kw • Hp)  
 Weight (kg • lbs)

550 • 1210  
 500 • 1100  
 85 - 140' • 25 - 40  
 386 • 15.2"  
 Twin Counter rot.  
 43.1 • 57.8  
 52.6 • 115.7

### Measurements

A (mm • in) 386 • 15.2  
 B (mm • in) 292 • 11.5  
 B max (mm • in) 372 • 14.65  
 C min. (mm • in) 380 • 15.0  
 D (mm • in) 500 • 19.7  
 D recommended (mm • in) 750 • 29.5  
 E min. (mm • in) 10 • 0.39  
 E max. (mm • in) 15 • 0.59

**Item Code**

**SH550/386TC-xxx**

### Stern Thrusters

F (mm • in) 257 • 10.12  
 G (mm • in) 540 • 21.25  
 C min. (mm • in) 380 • 15.00  
 H max. (mm • in) ∞  
 Tunnel length (mm • in) 550 • 21.65

### Item code

**Stern thruster kit** 90550  
**Cowls** 90560

## SH 1000/513 TC



Thrust up to (kg • lbs)  
 Typical boat size (ft • m)  
 Tunnel I.D. (mm • in)  
 Propulsion system  
 Hydraulic power up to (kw • Hp)  
 Weight (kg • lbs)

1000 • 2205  
 100 - 150' • 30 - 45  
 513 • 20"  
 Twin Counter rot.  
 63.0 • 84.5  
 146.5 • 323

### Measurements

A (mm • in) 513 • 20.2  
 B (mm • in) 483 • 19.1  
 C min. (mm • in) 700 • 27.6  
 D (mm • in) 750 • 29.5  
 D recommended (mm • in) 900 • 35.4  
 E recommended (mm • in) 16 • 0.63  
 E min/max. (mm • in) 12/22 • 0.47/0.87

**Item Code**

**SEI1000/513TC-xxx**

*Weight stated include thruster, props & bellhousing ONLY.  
 Weight of hydraulic motor (typical 25 - 40 kg) comes in addition*

*E recommended.: wall thickness of a standard Sidepower tunnel minimum/maximum wall thickness when using other GRP, steel or aluminium tunnels*

*E min/max:*

### Stern Thrusters

F (mm • in) 365 • 14.4  
 G (mm • in) 726 • 28.6  
 C min. (mm • in) 770 • 30.3  
 H max. (mm • in) ∞  
 Tunnel length (mm • in) 950 • 37.4

### Item code

**Stern thruster kit** 91000

## SH 1400/610 TC



Thrust up to (kg • lbs)  
 Typical boat size (ft • m)  
 Tunnel I.D. (mm • in)  
 Propulsion system  
 Hydraulic power up to (kw • Hp)  
 Weight (kg • lbs)

1400 • 3085  
 130 - 175' • 40 - 55  
 610 • 24"  
 Twin Counter rot.  
 87.8 • 117.7  
 170 • 375

### Measurements

A (mm • in) 610 • 24  
 B (mm • in) 500 • 19.1  
 C min. (mm • in) 830 • 32.7  
 D (mm • in) 750 • 29.5  
 D recommended (mm • in) 900 • 35.4  
 E recommended (mm • in) 18 • 0.71  
 E min/max. (mm • in) 14/24 • 0.55/0.94

**Item Code**

**SEI1400/610TC-xxx**

*Weight stated include thruster, props & bellhousing ONLY.  
 Weight of hydraulic motor (typical 25 - 40 kg) comes in addition*

*E recommended.: wall thickness of a standard Sidepower tunnel minimum/maximum wall thickness when using other GRP, steel or aluminium tunnels*

*E min/max:*

### Stern Thrusters

F (mm • in) 380 • 15.0  
 G (mm • in) 851 • 33.5  
 C min. (mm • in) 915 • 36.0  
 H max. (mm • in) ∞  
 Tunnel length (mm • in) 1000 • 39.4

### Item code

**Stern thruster kit** 91400

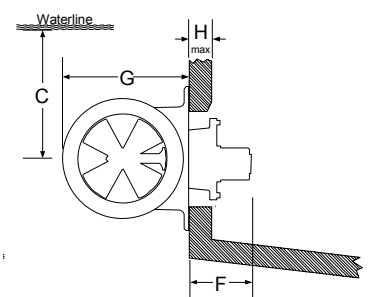
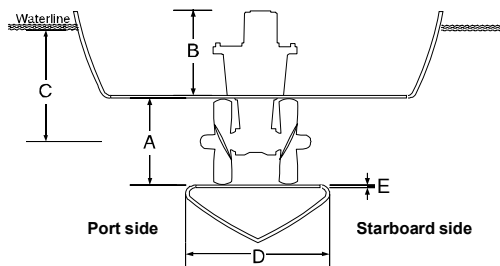
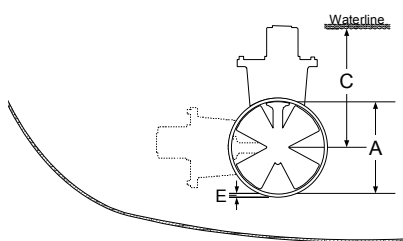

## Floor mounted

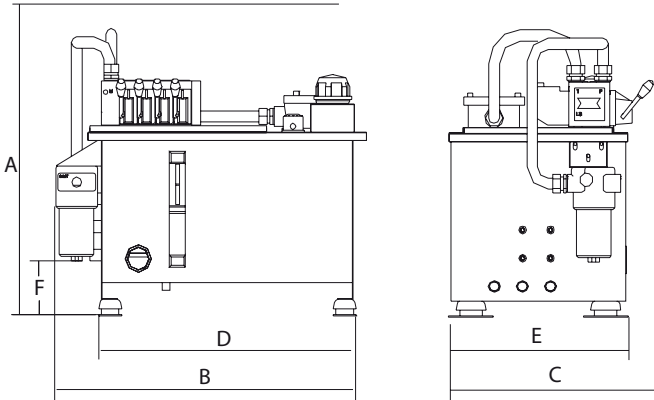

Tank kit	40 ltr	60 ltr	90 ltr	120 ltr
<b>Tank volume</b> (ltr • usg)	52.8 • 13.9	93.9 • 24.8	122.3 • 32.3	160 • 42.3
<b>Oil volume</b> (ltr • usg)	40 • 10.6	60 • 15.9	90 • 23.8	120 • 31.7
<b>Dry weight*</b> (kg • lbs)	46 • 101	60 • 132	68 • 154	77 • 170
<b>A</b> Build height (mm • in)	690 • 27.2	690 • 27.2	800 • 31.5	800 • 31.5
<b>B</b> Build length (mm • in)	785 • 30.9	800 • 31.5	800 • 35.1	1000 • 39.4
<b>C</b> Build depth (mm • in)	400 • 15.7	550 • 21.7	550 • 21.7	550 • 21.7
<b>D</b> Tank length (mm • in)	615 • 24.2	683 • 26.9	683 • 26.9	883 • 34.8
<b>E</b> Tank depth (mm • in)	340 • 13.4	479 • 18.9	479 • 18.9	479 • 18.9
<b>F</b> Filter change (mm • in)	100 • 4.0	100 • 4.0	100 • 4.0	100 • 4.0

\* with valve block for single thruster only

## Connections on tank

<b>1</b> Tank to pump	2" BSP
<b>2</b> Pump to valve	1" BSP
<b>3</b> Drain returns (3x)	1/2" BSP
<b>4</b> Valve ports to users	1/2" BSP
<b>5</b> Water to/from oil cooler	3/4" or 1" Nipple

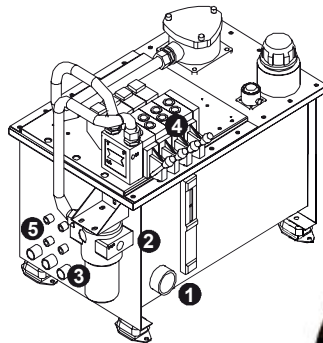

## Bulkhead mounted

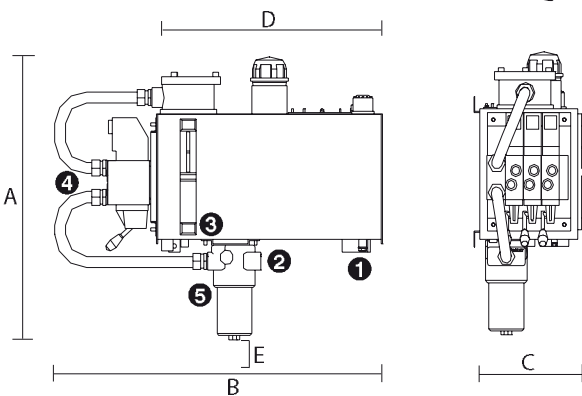

Tank kit	40 ltr	60 ltr
<b>Tank volume</b> (ltr • usg)	52.7 • 13.9	80 • 21.2
<b>Oil volume</b> (ltr • usg)	40 • 10.6	60 • 15.9
<b>Dry weight*</b> (kg • lbs)	45 • 99	59 • 130
<b>A</b> Build height (mm • in)	705 • 27.8	860 • 33.6
<b>B</b> Build length (mm • in)	870 • 34.3	890 • 35.0
<b>C</b> Build depth (mm • in)	330 • 13.0	330 • 13.0
<b>D</b> Tank length (mm • in)	600 • 23.6	600 • 23.6
<b>E</b> Filter change (mm • in)	100 • 4.0	100 • 4.0

Connections on tank	
<b>1</b> Tank to pump	2" BSP
<b>2</b> Pump to valve	1" BSP
<b>3</b> Drain returns (3x)	1/2" BSP
<b>4</b> Valve ports to users	1/2" BSP
<b>5</b> Water to/from oil cooler	3/4" or 1" Nipple

\* with valve block for single thruster only





# S-link System

S-link is a "CAN" based control system with full intelligent communication between all units in the system, much like a computer network.

Main advantages include:

- Round, compact and waterproof plugs with unique keying and color coding to avoid faulty hookup
- Unlimited number of commands or information transfer on a single cable
- User feedback at panel
- Intelligent troubleshooting

## S-link cable component overview

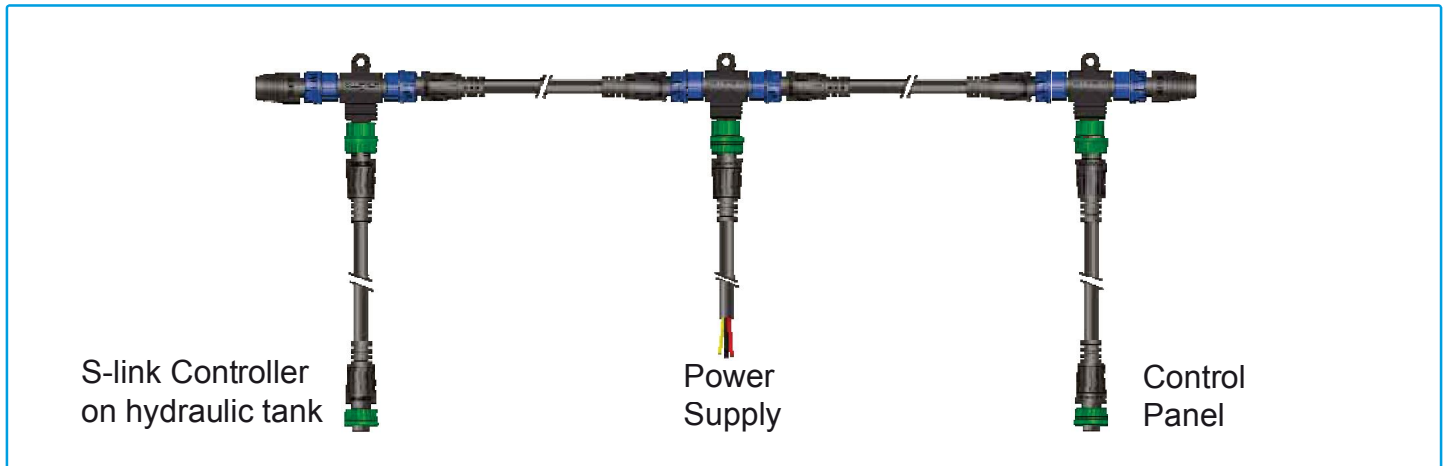

### BACKBONE cables

Forms the main "loop" around the boat.

Part #: 6 1320-xxM (xx=length)

- 6 1320-0,2M (0,2m)
- 6 1320-2M (2,0m)
- 6 1320-4M (4,0m)
- 6 1320-7M (7,0m)
- 6 1320-10M (10,0m)
- 6 1320-15M (15,0m)
- 6 1320-20M (20,0m)



### SPUR cables

Must be used to connect all parts to the backbone cable (one for each component, no exceptions), recommended to be as short as practically possible.

Part #: 6 1321-xxM (xx=length)

- 6 1321-0,4M (0,4m)
- 6 1321-1M (1,0m)
- 6 1321-3M (3,0m)
- 6 1321-5M (5,0m)

### POWER cable

Must be one in each system, length 2.5m

Part #: 6 1328



### BACKBONE EXTENDER

Connects two backbone cables to extend length.

Part #: 6 1322



### T-CONNECTOR

Must be one for each spur, including power cable.

Part #: 6 1326



### END TERMINATOR

Must be one in each end of the backbone "loop".

Part #: 6 1327





## S-link system examples

Example of the control wiring with S-link system for boats with two control positions and hydraulic thruster system.

Depending on the boat's construction, there might be several different ways to route the S-link backbone.

Find the most practical way to implement the backbone and remember that the S-link equipment do not need to be connected in a specific order.

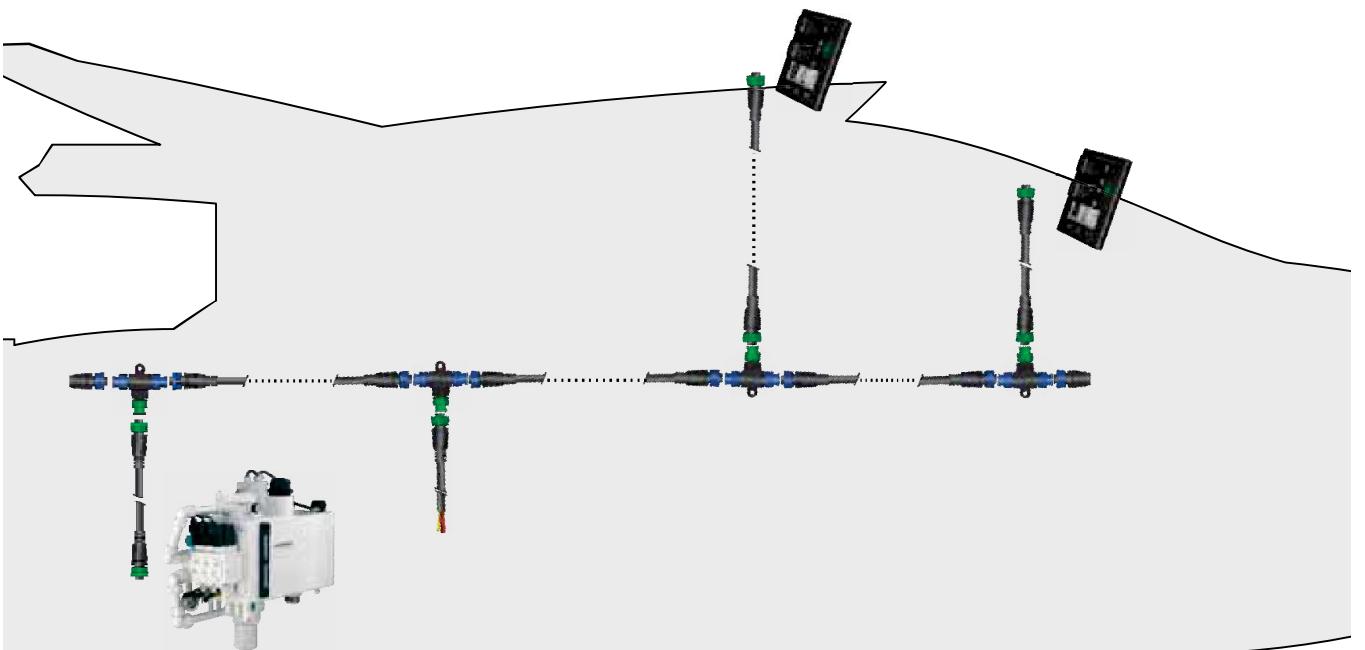
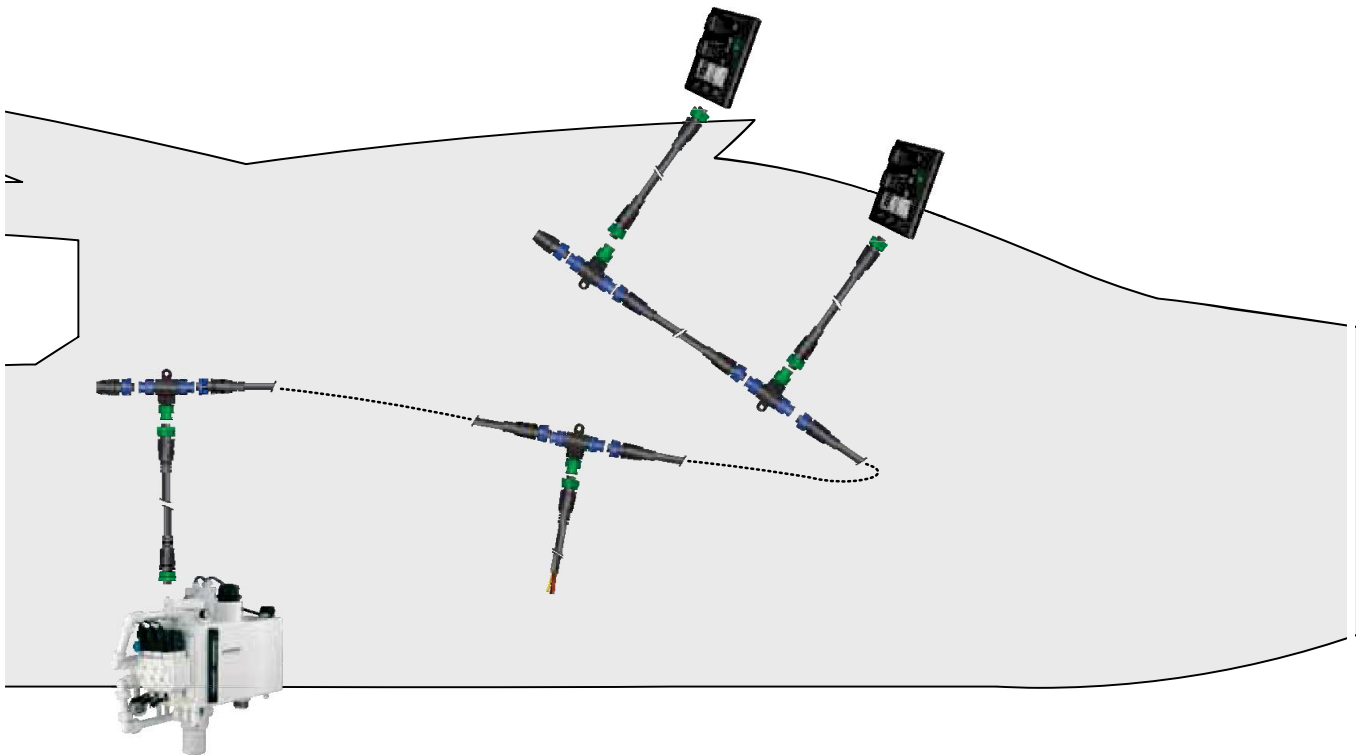



## PJC 221/222 - Single/ Dual Joystick

- For proportional thruster control with S-link hydraulic thruster systems
- Finger tip control speed control with purpose designed joysticks
- Hold - function for easy docking, runs thrusters at selected power (dual panel only)
- Compact design
- Back-lit LCD display with instant feedback
  - System status
  - Amount of thrust & direction of thrust
  - Oil temperature
- Interactive multi-language menus
- CAN-Bus communication with thrusters and accessories
- Plug & play cables, waterproof and compact connectors
- Built-in audible alarm “buzzer”
- Connector for external “buzzer”/loud audible alarms

Singel		Dual	
H (mm • in)	141 • 5.55	H (mm • in)	141 • 5.55
W (mm • in)	83 • 3.27	W (mm • in)	83 • 3.27
<b>Item code (12 &amp; 24V)</b>	<b>PJC211</b>	<b>Item code (12 &amp; 24V)</b>	<b>PJC212</b>



## PJC 321/322 - Single/ Dual Joystick PRO

- For proportional thruster control with S-link hydraulic thruster systems
- “Twist & Hold”-function on joysticks
- Separate back-lit LCD display with instant feedback
  - System status
  - Amount of thrust & direction of thrust
  - Oil temperature & pressure
- Interactive multi-language menus
- CAN-Bus communication with thrusters and accessories
- Plug & play cables, waterproof and compact connectors
- Diagnostics via panel
- Connector for external “buzzer”/loud audible alarms

Singel		Dual	
H (mm • in)	141 • 5.55	H (mm • in)	141 • 5.55
W (mm • in)	83 • 3.27	W (mm • in)	83 • 3.27
<b>Item code (12 &amp; 24V)</b>	<b>PJC211</b>	<b>Item code (12 &amp; 24V)</b>	<b>PJC212</b>

## 150200 S-link Gateway

The S-Link gateway is the way to access full proportional control of the thrusters from another controller that can output CanBus signals and use the thrusters proportionally. A license from Sleipner is necessary, and today for example the ZF’s JMS joystick control can do this.

H (mm • in)	45 • 1.77
W (mm • in)	80 • 3.15
D (mm • in)	145 • 5.70
<b>Item code (12 &amp; 24V)</b>	<b>150200</b>

## 8730 S-link Interface

S-link interface to connect footswitches and standard radio remotes/control panels to a S-link system (Footswitches/Panels/Radio Remote not included).

Add a Radio Remote to your S-link system for even easier short handed boating, or footswitches for hands-free operation of your S-link thrusters.



Interface Box	
H (mm • in)	45 • 1.77
W (mm • in)	80 • 3.15
D (mm • in)	145 • 5.70
<b>Item code (12 &amp; 24V)</b>	<b>8730</b>





Sleipner Motor AS  
P.O. Box 519,  
N-1612 Fredrikstad, Norway  
Tel: +47 69 30 00 60  
Fax: +47 69 30 00 70

## Other catalogs:

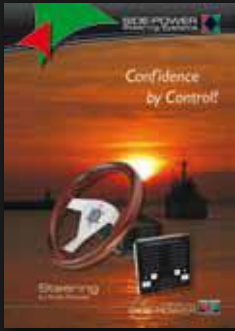

Steering  
Systems



Stabilizer  
Systems

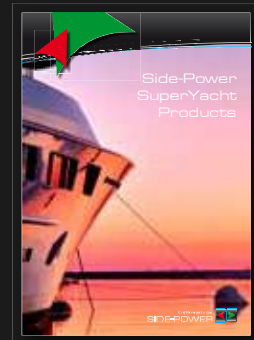

Superyacht  
Products



Large  
Thrusters

## Worldwide sales and service



**SAILTEC**

SAILTEC Projekt GmbH  
Hasselbinnen 28  
D-22969 Schenefeld

+49 40 822994-0  
info@sailtec.eu  
www.sailtec.eu



Confidence by Control

**SIDE-POWER.com**

Your contact