



With counter rotating four-bladed propellers, mechanically built like its larger brothers, the reliable and powerful SE170/210TC-IP thruster has become the market leader in its size range. The SE170/250TC-IP includes all the important and unique **Side-Power** features and qualities - **why settle for less**

#### THRUSTER DATA

Thrust at 21V* (kg · lbs)	170 · 374
Thrust at 24V* (kg · lbs)	210 · 462
Typical boat size (ft · m)	50 - 70 · 15 - 22
Tunnel I.D. (mm · in)	250 · 9.8
Propulsion system	Twin counter rot.
Power at 21V* (kw · Hp)	8 · 10.7
For DC system (V)	24
Weight (kg · lbs)	45 · 99
Min. Batt. Cap (CCA 24V)	550
<b>Item Code 24V</b>	SE170/250TC-IP

#### Measurements

A (mm · in)	250 · 9.84
B (mm · in)	451 · 17.8
C (mm · in)	308 · 12.1
D (mm · in)	382 · 15.0
E min (mm · in)	250 · 9.8
F (mm · in)	300 · 11.8
F recommended (mm · in)	600 · 23.6
G min. (mm · in)	7 · 0.28
G max. (mm · in)	10 · 0.39

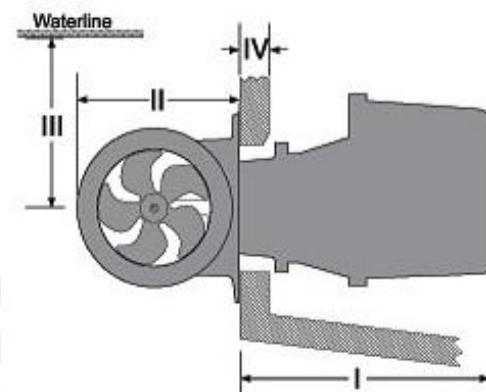
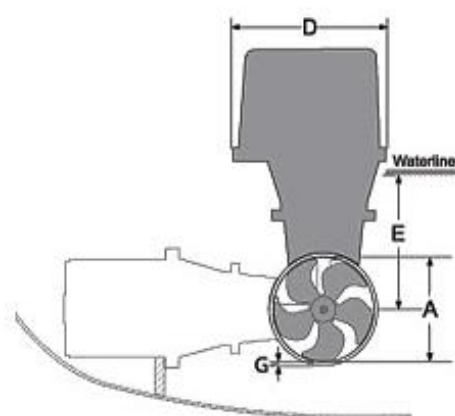
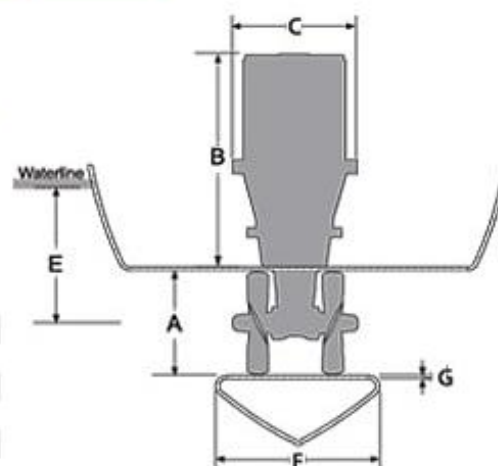

AVAILABLE WITH  
SPEED CONTROL  
(INCL. PPC800)

#### STERN THRUSTER KIT

##### Measurements

I (mm · in)	407 · 16.0
II (mm · in)	340 · 13.4
III min. (mm · in)	250 · 9.8
IV max. (mm · in)	60 · 2.4
V (mm · in)	200 · 7.9
VI (mm · in)	350 · 13.9
Tunnel length (mm · in)	350 · 13.9

##### Item code

Stern thruster kit	90140i/90150i
Cowls - short model	90132



SAILTEC GmbH - Hasselbinnen 28 - D-22869 Schenefeld  
Tel. +49-(0)40-8229940 - Fax +49-(0)40-8304279  
Email [info@sailtec.de](mailto:info@sailtec.de) - Internet [www.sailtec.de](http://www.sailtec.de)