



With its outstanding energy efficiency and unrivalled reliability, the **SE60/185S-IP** is the *classic* and best selling thruster in the **Side-Power** series and includes all the important and unique **Side-Power** features and qualities - **why settle for less.**

#### THRUSTER DATA

Thrust at 10.5V/21V* (kg · lbs)	60 · 132
Thrust at 12V/24V* (kg · lbs)	73 · 161
Typical boat size (ft · m)	29 - 38 · 9 - 12
Tunnel I.D. (mm · in)	185 · 7.3
Propulsion system	Single
Power at 10.5V/21V* (kw · Hp)	3.1 · 4
For DC system (V)	12/24
Weight (kg · lbs)	17 · 37
Min. Batt. Cap (CCA 12/24V)	350 · 175
<b>Item Code 12V</b>	SE60/185S-12IP
<b>Item Code 24V</b>	SE60/185S-24IP

#### Measurements

A (mm · in)	185 · 7.3
B (mm · in)	270 · 10.6
C (mm · in)	230 · 9.1
D (mm · in)	272 · 10.7
E min (mm · in)	150 · 5.9
F (mm · in)	117 · 4.6
F recommended (mm · in)	234 · 9.2
G min. (mm · in)	4 · 0.16
G max. (mm · in)	6 · 0.24

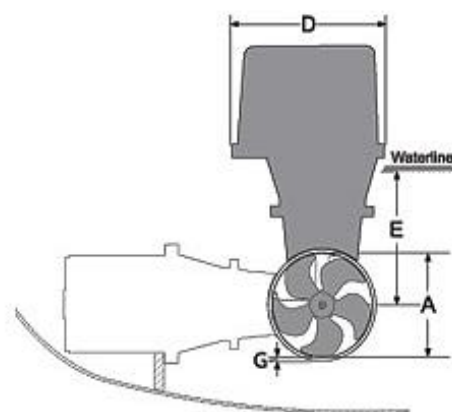
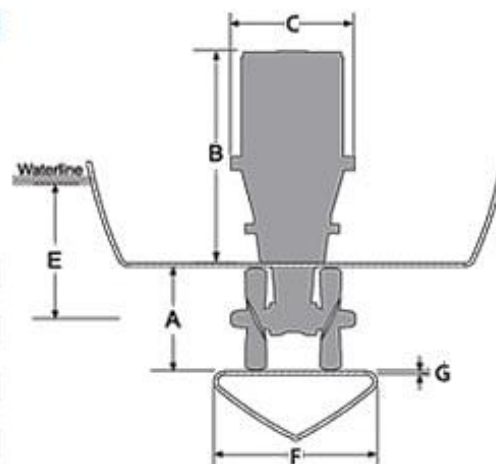

#### STERN THRUSTER KIT

##### Measurements

I (mm · in)	265 · 10.4
II (mm · in)	256 · 10.1
III min. (mm · in)	150 · 5.9
IV max. (mm · in)	35 · 1.4
V (mm · in)	200 · 7.8
VI (mm · in)	300 · 11.8
Tunnel length (mm · in)	337 · 13.3

##### Item code

Stern thruster kit	90052i
Cowls - short model	90075
Cowls - long model	90077

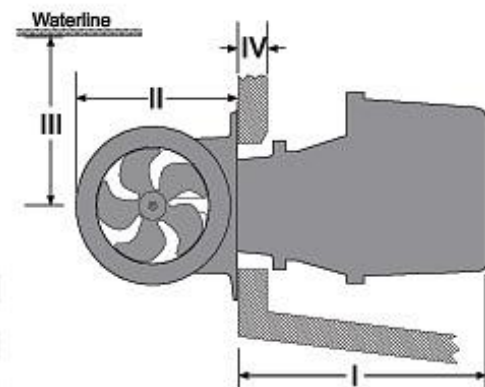

SAILTEC GmbH - Hasselbinnen 28 - D-22869 Schenefeld  
 Tel. +49-(0)40-8229940 - Fax +49-(0)40-8304279  
 Email [info@sailtec.de](mailto:info@sailtec.de) - Internet [www.sailtec.de](http://www.sailtec.de)