

NEW!

King Cobra

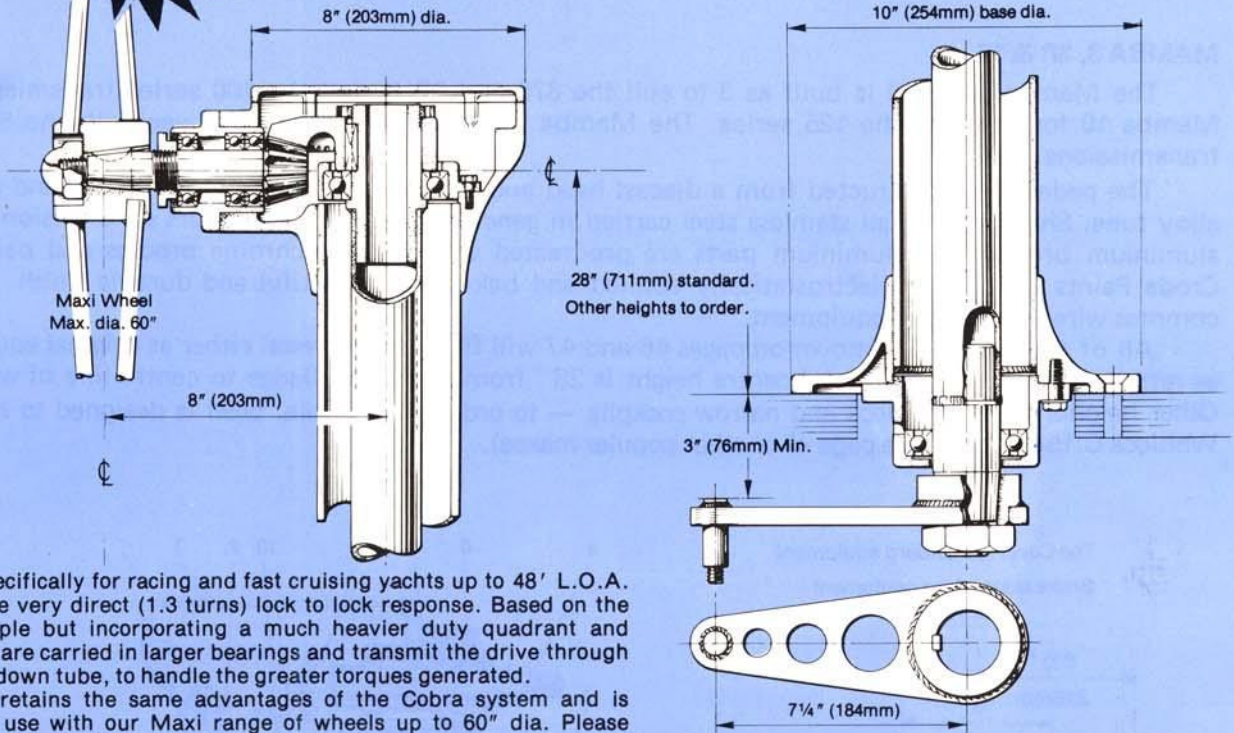

Designed specifically for racing and fast cruising yachts up to 48' L.O.A. which require very direct (1.3 turns) lock to lock response. Based on the Cobra principle but incorporating a much heavier duty quadrant and pinion which are carried in larger bearings and transmit the drive through a larger dia. down tube, to handle the greater torques generated. King Cobra retains the same advantages of the Cobra system and is intended for use with our Maxi range of wheels up to 60" dia. Please discuss applications with our design staff.

Python and Python 'R'

“The perfect steering solution for yachts from 40' to 60'”

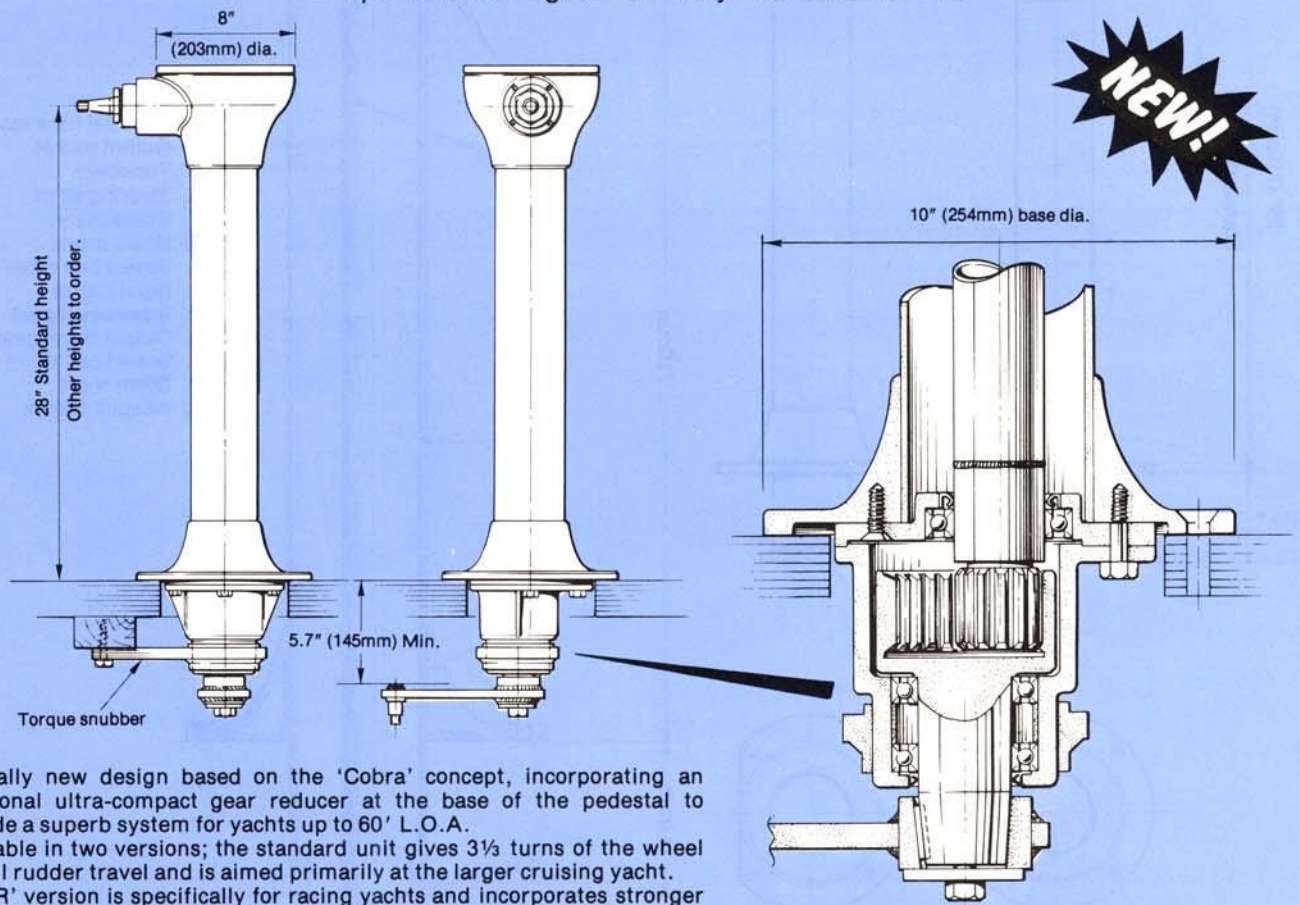

A totally new design based on the 'Cobra' concept, incorporating an additional ultra-compact gear reducer at the base of the pedestal to provide a superb system for yachts up to 60' L.O.A. Available in two versions; the standard unit gives 3 1/3 turns of the wheel for full rudder travel and is aimed primarily at the larger cruising yacht. The 'R' version is specifically for racing yachts and incorporates stronger gear sections and larger bearings. It is offered with a range of custom ratios giving between 1.6 and 2.6 turns at the wheel and is designed to be used in conjunction with wheels up to 60" diameter.

“The precision, strength & simplicity of installation of the Cobra system extended to yachts up to 60'.”