

Rack & Pinion Systems **King Cobra**

for racing yachts ...

Designed specifically for racing and fast cruising yachts up to 55' L.O.A. which require very direct (1.3 turns) lock to lock response. Based on the Cobra principle but incorporating a much heavier duty quadrant and pinion which are carried in larger bearings and transmit the drive through a larger dia. down tube, to handle the greater torques generated.

King Cobra retains the same advantages of the Cobra system and is intended for use with our Maxi range of wheels up to 60" dia. Please discuss applications with our design staff.

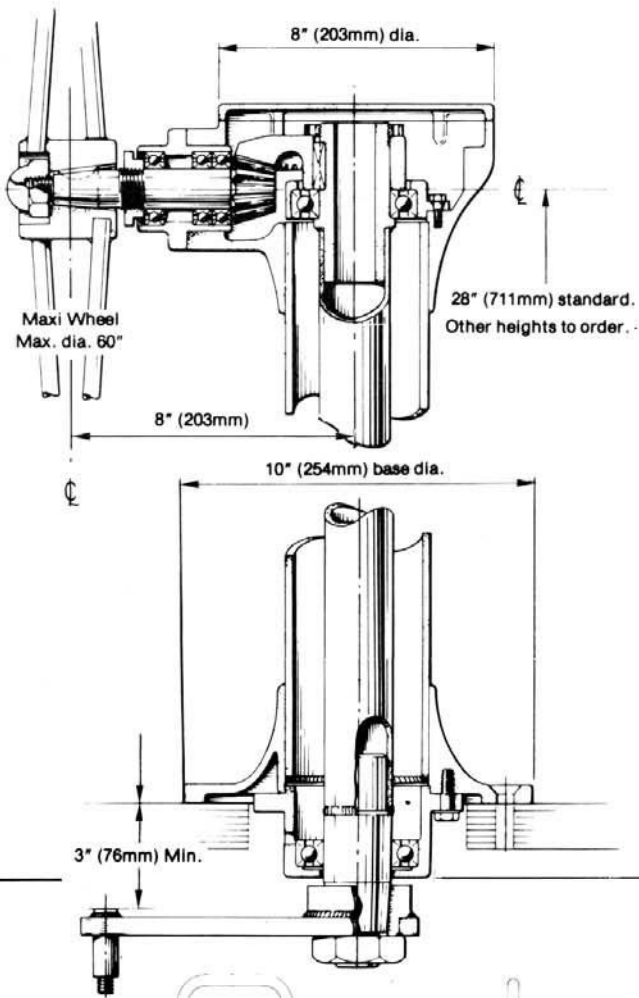

Custom installation of King Cobra incorporating shortened pedestal, bearing extender and torque plate.

